

Original instructions

ENG 5/25

OPERATOR'S MANUAL

OM1655ESENG.525

Rammer[®]

HYDRAULIC HAMMER

RAMMER 1655E

STD

| | | | |
|--|-----------|---|-----------|
| OPERATION | 3 | Removal of tool | 62 |
| 1. Foreword | 4 | Installation of tool | 63 |
| This manual | 4 | 3. Changing the lower tool bushing. | 64 |
| Important safety information | 6 | Wear limits and lubricants | |
| Warranty. | 6 | for lower tool bushing | 64 |
| Spare part orders. | 7 | Removal of lower tool bushing. | 66 |
| 2. Product numbers. | 8 | Installation of lower tool bushing. | 68 |
| Model and serial number | 8 | 4. Troubleshooting. | 70 |
| 3. Product introduction. | 9 | The hammer does not start. | 70 |
| Overview. | 9 | The hammer operates irregularly | |
| Removal from package | 9 | but the blow has full power | 71 |
| Lifting instructions | 9 | The hammer operates irregularly | |
| Main parts | 13 | and blow has no power | 71 |
| Ramvalve | 14 | Impact rate slows down | 72 |
| Greasing device | 14 | The hammer does not stop | |
| Remote monitoring device. | 14 | or has run-on | 72 |
| Environmental protection | | Oil overheats | 73 |
| and recycling policy. | 16 | Recurrent tool failure | 73 |
| 4. Safety | 17 | Automatic greasing device problems. | 74 |
| General safety | 17 | Further assistance | 75 |
| Safety instructions. | 18 | SPECIFICATIONS | 77 |
| 5. Operation | 27 | 1. Hammer specifications | 78 |
| Operating instructions. | 27 | Technical specifications | 78 |
| Daily operation | 32 | Main dimensions | 79 |
| Mounting and dismounting the hammer | 40 | Mounting bracket specifications. | 80 |
| Movement. | 41 | 2. Tool specifications | 81 |
| Special conditions of use | 41 | 3. Compliance | 82 |
| Storage | 43 | EU Declaration of Conformity | 82 |
| LUBRICATION | 45 | UK Declaration of Conformity | 83 |
| 1. Hammer tool greasing. | 46 | | |
| Recommended greases. | 46 | | |
| Automatic greasing | 47 | | |
| Adjusting the dose. | 48 | | |
| Manual greasing | 50 | | |
| 2. Carrier hydraulic oil | 52 | | |
| Requirements for hydraulic oil | 52 | | |
| Oil cooler | 54 | | |
| Oil filter | 55 | | |
| MAINTENANCE | 57 | | |
| 1. Routine maintenance | 58 | | |
| Overview. | 58 | | |
| Inspection and maintenance | | | |
| by the operator | 58 | | |
| Inspection and maintenance | | | |
| by the dealer | 59 | | |
| Maintenance intervals | | | |
| in special applications | 60 | | |
| Other maintenance procedures | 60 | | |
| 2. Changing the tool | 61 | | |
| Wear limits and lubricants | | | |
| for tool removal | 61 | | |

OPERATION

1. FOREWORD

1.1 THIS MANUAL

BG: Поискайте от дистрибутора на Rammer версия на български език на това ръководство.
CS: Českou/Slovenskou verzi této příručky získáte o vašeho prodejce společnosti Rammer.
DA: Bed om en dansksproget version af denne manual hos din Rammer-forhandler.
DE: Fragen Sie Ihren Rammer-Händler nach der deutschen Fassung dieses Handbuchs.
EL: Ζητήστε την ελληνική έκδοση του παρόντος εγχειριδίου από τον τοπικό αντιπρόσωπο της Rammer.
EN: Ask for the English language version of this manual from your Rammer dealer.
ES: Pídale a su distribuidor de Rammer la versión en español de este manual.
ET: Käesoleva kasutusjuhendi eestikeelse versiooni saate Rammeri edasimüüjalt.
FI: Pyydä suomenkielinen ohjekirja Rammer-jälleenmyyjältäsi.
FR: Adressez-vous à votre revendeur Rammer pour obtenir la version française de ce manuel.
HR: Hrvatsku verziju ovog priručnika zatražite od zastupnika tvrtke Rammer.
HU: Ez a kézikönyv magyar nyelven is elérhető, kérje Rammer forgalmazójától.
IS: Biðjið Rammer dreifingaraðila ykkar um íslenska útgáfu af þessari handbók.
IT: È possibile richiedere la versione in lingua italiana di questo manuale presso il rivenditore Rammer.
LT: Paprašykite savo Rammer platintojo lietuviškos instrukcijos versijos.
LV: Rokasgrāmatas tulkojumu latviešu valodā jautājiem savam Rammer dālerim.
NL: Vraag bij uw Rammer-dealer naar de Nederlandse versie van deze gebruiksaanwijzing.
NO: Be om den norske versjonen av denne håndboken fra din Rammer-leverandør.
PL: Proszę zwrócić się do dystrybutora Rammer, aby otrzymać niniejszą instrukcję w języku polskim.
PT: Solicite a versão em português deste manual ao seu representante Rammer.
RO: Solicitați versiunea în limba română a acestui manual de la distribuitorul dumneavoastră Rammer.
RU: Запросите версию данного руководства на русском языке у вашего дилера компании Rammer.
SK: Českú/Slovenskú verziu tejto príručky získate u svojho predajcu spoločnosti Rammer.
SL: Vprašanje svojega Rammer predstavnika za ta priročnik v slovenskem jeziku.
SR: Tražite verziju ovog priručnika na srpskom jeziku od vašeg Rammer dilera.
SV: Be om den svenskspråkiga versionen av denna manual hos din Rammer-återförsäljare.
TR: Bu kılavuzun Türkçe versiyonunu Rammer temsilcinizden isteyebilirsiniz.

R010483

This manual is arranged to give you a good understanding of the equipment and its safe operation. It also contains maintenance information and technical specifications. Read this manual from front to back before installing, operating or maintaining the attachment for the first time.

In this manual, the units of measurement are metric. For example, weights are given in kilograms (kg). In some cases the other unit follows in parenthesis (). For example 28 litres (7.4 US gal).

The specifications and designs presented in this manual are subject to change without prior notice.

SYMBOLS USED IN THIS MANUAL

This symbol identifies important safety messages within this manual. Carefully read the message that follows. Failure to understand and obey this safety warning could result in injury to you or others, and could also cause damage to equipment. See illustration 1.

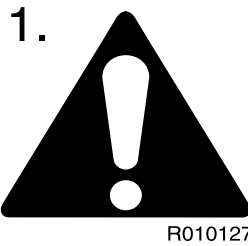

This symbol identifies a prohibited action or a hazardous location. Failure to understand and obey this safety warning could result in injury to you or others, and could also cause damage to equipment. See illustration 2.

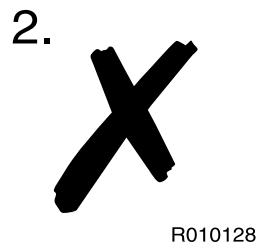

This symbol identifies correct and recommended action. See illustration 3.

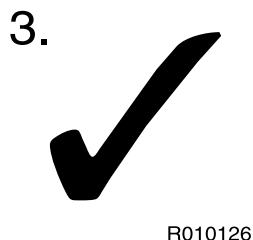

This symbol identifies environmental and recycling matter. See illustration 4.

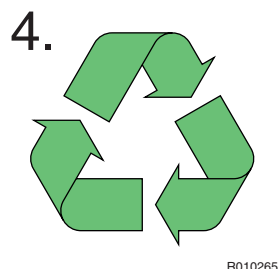

1.2 IMPORTANT SAFETY INFORMATION

Basic safety precautions are outlined in the "Safety" section of this manual and in the description of operations where hazards exist. Warning labels have also been put on the machine to provide instructions and to identify specific hazards which if not observed could cause bodily injury or death to you or other persons. These warnings in the guide and on the machine labels are identified by the warning symbol.

To use the attachment correctly, you must also be a competent operator of the carrier machine. Do not use or install it if you cannot use the carrier machine properly. The attachment is a powerful tool. If used without proper care, it can cause damage.

Do not rush when you are learning to use the product. Take your time and most importantly, take it safely. Do not guess. If there is anything you do not understand, ask your local dealer.

Improper operation, lubrication or maintenance of this machine can be dangerous and could result in injury.

Do not operate this machine until you have read and understood the instructions in this manual.

Do not perform any lubrication and maintenance on this machine until you have read and understood the instructions in this manual.

1.3 WARRANTY

Check that a separate warranty sheet explaining the export warranty terms is delivered with the attachment. If not, contact your local dealer immediately.

WARRANTY REGISTRATION

After the installation inspection, the dealer completes a warranty registration form online in the Distributor Portal and sends it to the manufacturer. This form is very important because warranty claims will not be handled without it. Make sure that you get a copy of the warranty registration form after the installation inspection and that it has been correctly filled out.

INSTALLATION INSPECTION

An installation inspection must be carried out after the product has been installed on the carrier. In the installation inspection certain specifications (such as operating pressure and oil flow) are checked so that they are within given limits. See "Hammer specifications" on page 78.

1.4 SPARE PART ORDERS

When you need spare parts or some information concerning maintenance to your machinery, please contact your local dealer. Quick deliveries are ensured by exact orders.

Required information:

- Name of customer and contact person
- Order number (when available)
- Delivery address
- Mode of delivery (air mail etc.)
- Required delivery date
- Invoicing address
- Model and serial number of product
- Name, number and required amount of spare parts

2. PRODUCT NUMBERS

2.1 MODEL AND SERIAL NUMBER

The product serial number is stamped on the valve body. Both the model and serial number are located on the product identification plate. Check that the model corresponds to the one given on the cover of this manual.

It is important to make correct reference to the serial number of the attachment when making repairs or ordering spare parts. Identification of the serial number is the only proper means of maintaining and identifying parts for a specific product.

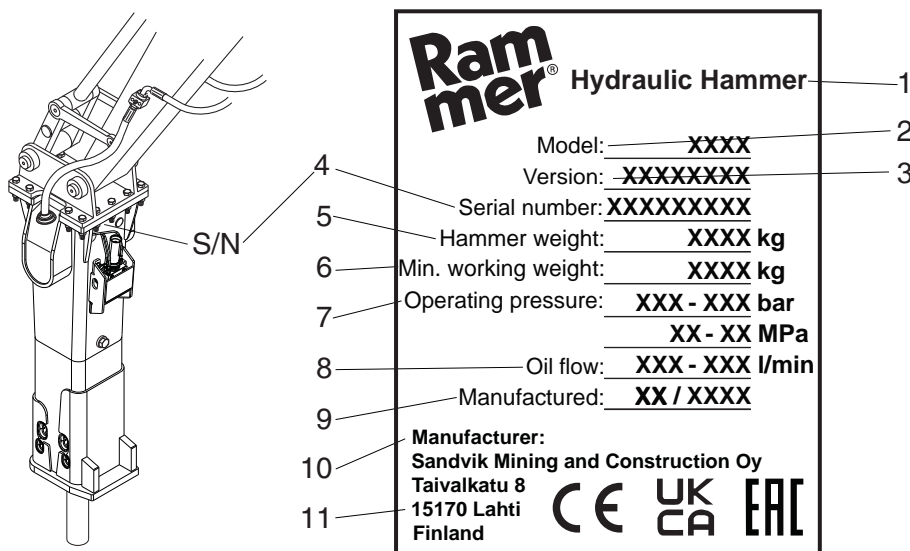

R010531

CONTENT OF THE PRODUCT IDENTIFICATION PLATE

| | |
|----|------------------------------------|
| 1 | Hydraulic Hammer |
| 2 | Model |
| 3 | Version |
| 4 | Serial Number |
| 5 | Hammer weight (kg) |
| 6 | Min working weight (kg) |
| 7 | Operating pressure (bar) |
| 8 | Oil flow (l/min) |
| 9 | Manufactured or Manufacturing date |
| 10 | Manufacturer |
| 11 | Address |

3. PRODUCT INTRODUCTION

3.1 OVERVIEW

The product is a hydraulically operated hammer. It can be used on any carrier which meets the necessary hydraulic and mechanical installation requirements. The unit functions by repeatedly raising a steel piston and driving it down onto the head of a removable breaking tool.

No additional pressure accumulators are necessary since the integrated pressure accumulator absorbs hydraulic pressure peaks. The impact energy of the hammer is almost constant and independent of the carrier's hydraulic system.

3.2 REMOVAL FROM PACKAGE

Remove all the steel belts from the package. Open the package and remove all plastics covering the product.



Recycle all package materials (steel, plastic, wood) properly.

Check that the product is in good condition and that there is no visible damage. Check that all ordered parts and accessories have been enclosed with the product. Some options may be provided by your local dealer like installation kits; including hoses and mounting bracket.

3.3 LIFTING INSTRUCTIONS

Use a hoist when lifting components which weigh 23 kg (50 lb) or more, to avoid back injury. Make sure all lifting equipment is in good condition and are in the correct capacity. Be sure hooks are positioned correctly. Lifting eyes are not to be side loaded during a lifting operation. Do not use the hammer's tools for lifting.

PROVIDED LIFTING POINTS

Use the lifting eyes located on the product housing only to lift or handle the product itself. The lifting capacity calculation is based on the product's working weight including a normal working tool and an average sized mounting bracket.



Warning! To avoid falling objects, do not use the product to lift other products. Use the lifting eyes located on the product housing only to lift or handle the product itself.

The maximum allowed total weight is shown on the product's CE-plate and specification page. See "Hammer specifications" on page 78. If the weight exceeds the maximum allowed total weight shown on the CE-plate and specification page, you have to use other lifting points/methods than originally provided on the product.

The other threaded holes on the product (for example on the hammer impact unit) are intended for handling single parts only. It is forbidden to lift the entire assembly by using these threaded holes (for example on the cylinder outer surfaces). For handling the parts, see product workshop documentation for suitable lifting methods and lifting adapters.

LIFTING EYE SCREWS

Tighten the lifting eye screws completely. Put a burden on the lifting eye only if the screw is properly tightened to the housing.



Warning: Failure to completely tighten the lifting eye screw before lifting the product or part may result in failure of the lifting eye screw and cause the product or part to fall.

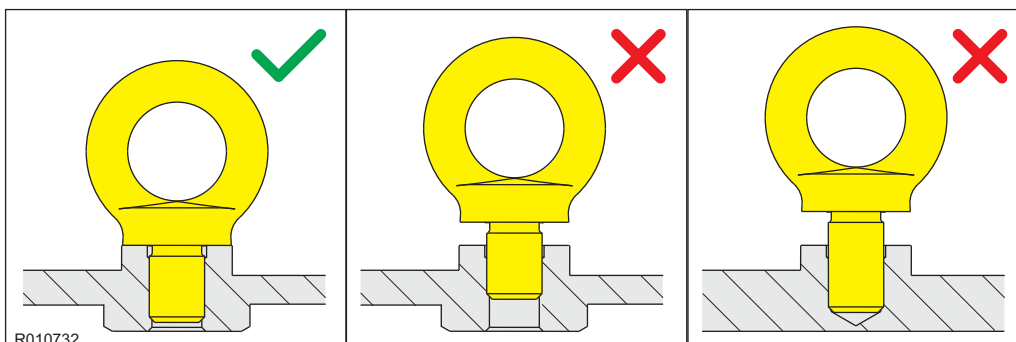

If you use mechanical tools for tightening, make sure not to overstrain the shank. Before lifting make sure that the chain and/or hook is stretched.

When two lifting eye screws are used, the lifting capacity depends on the angle of the lifting chains. The angle should not be less than 45° , as shown in the illustration. When the lifting eye screws are tightened, both rings should be aligned.

The loading capacity calculation applies to temperatures between -10°C (14°F) and 40°C (104°F).

Before reuse of lifting eye screws make sure there are no surface flaws (for example rust, pits, voids, folds and seams, deformation of the ring, or missing or broken threads).

The local, national safety standards for machines and lifting-equipments must always be strictly observed.

Note: Before starting to operate the hammer, always replace the lifting eye with a blanking screw.

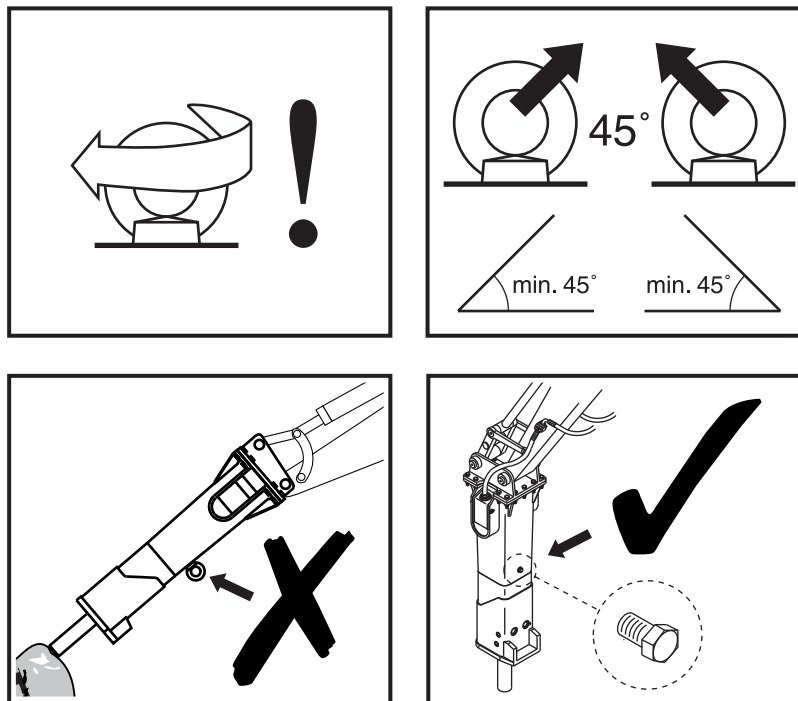

R010266

Lifting devices must safely carry the working weight of the product. See “Hammer specifications” on page 78. Place chains or slings, as shown by the illustration, to lift the product.

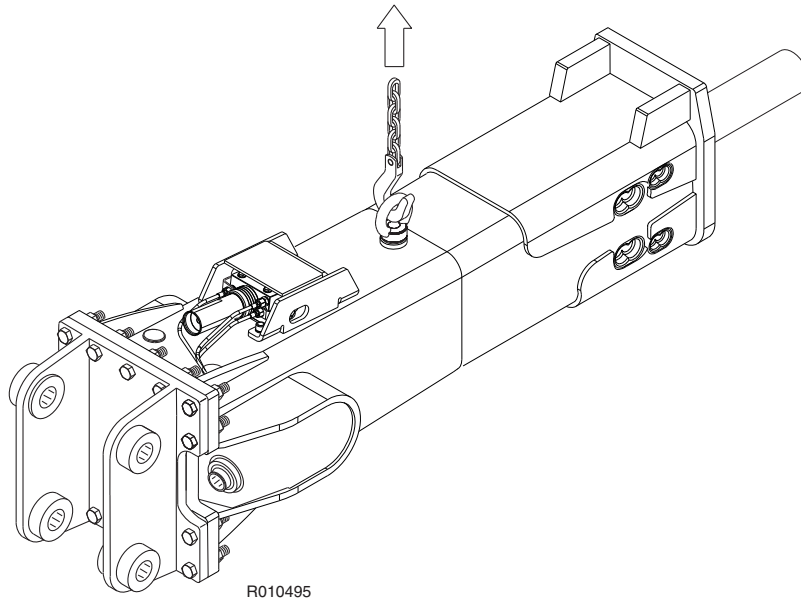

Note: Before starting to operate the hammer, always replace the lifting eye with a blanking screw.

SAFETY INSTRUCTIONS FOR LIFTING

Below are some common safety instructions concerning lifting operations. In addition to this, the local, national standards for machines and lifting-equipments must always be strictly observed. Please note that the list below is not all inclusive, you must always ensure the procedure you choose is safe for you and others.

- Do not lift load over people. No one shall be under the hoisted load.
- Do not lift people and never ride the hoisted load.
- Keep people clear from lift area.
- Avoid side pull of the load. Make sure you take up the slack slowly. Start and stop carefully.
- Lift the load a few centimeters and verify it before proceeding. Make sure the load is well balanced. Check for any loose items.
- Never leave the suspended load unattended. Maintain load control at all times.
- Never lift the load over the rated capacity (see product's operating weight from specification page).
- Inspect all lifting equipment before use. Do not use twisted or damaged lifting equipment. Protect lifting equipment from sharp corners.
- Obey all local safety instructions.

3.4 MAIN PARTS

The main parts of the hammer are shown below.

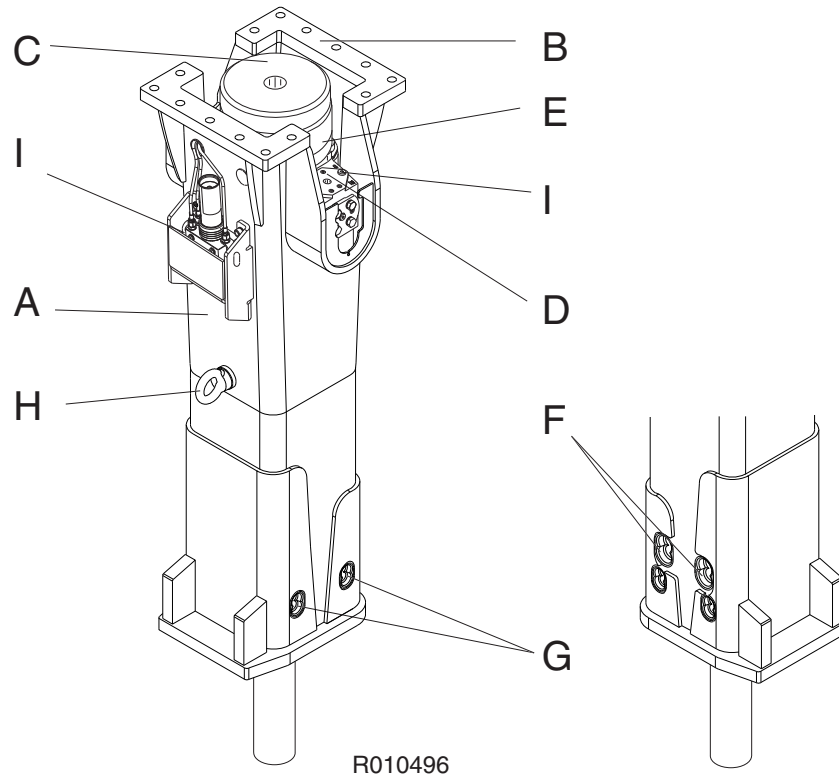

- A. Housing
- B. Mounting flange
- C. Vibration dampening elements
- D. Hose connections (pressure and return lines, automatic lubrication and pressurized air)
- E. Pressure accumulator
- F. Tool retaining mechanism
- G. Lower tool bushing retaining mechanism
- H. Lifting eye
- I. Greasing device/Grease nipples

3.5 RAMVALVE

The hammer is equipped with a built-in Ramvalve.

The Ramvalve is designed to decrease oil flow remarkably to the hammer when oil flow from the carrier is too high.

If the impact rate of the hammer decreases suddenly when operating the hammer, contact your local carrier dealer to decrease the carrier's oil flow.

3.6 GREASING DEVICE

The hammer can be equipped with an automatic greasing device. The tool grease is supplied from the greasing device into the hammer by the grease lines. See "Automatic greasing" on page 47.

Advantages of the automatic lubrication system are:

- Longer service life for wear parts
- Higher utilization rate of the hammer
- Possibility to grease manually
- Reduced grease waste

Note: Some hammer models are equipped with an adapter kit for manual greasing and do not include an automatic greasing device.

3.7 REMOTE MONITORING DEVICE

The remote monitoring device is a hammer-mounted unit that collects and data on hammer operation and location. The data is available through an online so that you can remotely manage one or more hammers. For example, in the online service, you can view hammer work history, manage service schedules, optimize hammer performance, plan operator training and conduct fleet management.

See the "Remote monitoring device" guide for technical specifications and installation instructions.

For more information, contact your local Rammer dealer.

Note: The equipment data can be viewed in the online service, SAM. To access SAM, go to <https://sam.rockprocessing.sandvik/> or install the SAM mobile app to your mobile device. For more information, see the mobile app guide for the SAM digital service.

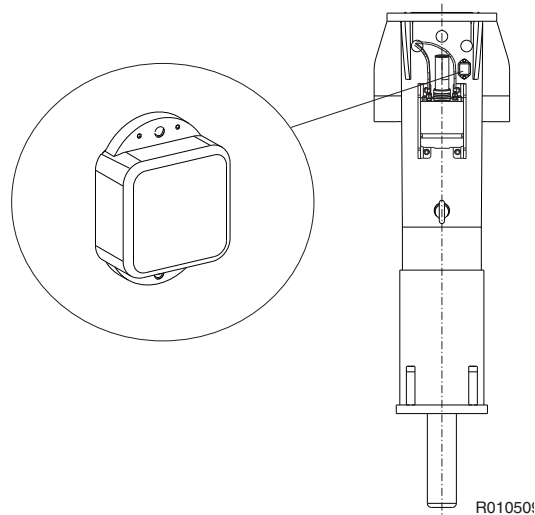

Warning! RD3/RD3X contains a SIM card to enable remote connections and an encased lithium metal battery. Both items are regulated for air transport. Consult your forwarder about any restrictions for air freight.



Warning! Lithium is a highly flammable substance. Store damaged lithium batteries in a fire proof container. Never transport a damaged or unprotected lithium battery. Follow local laws and regulations on proper disposal of damaged lithium batteries.



Warning! Inhalation, skin contact and eye contact can occur when the battery is opened. Upon exposure to internal contents, the corrosive fumes will be very irritating to the skin, eyes and mucous membranes. Overexposure can cause symptoms of non-fibrotic lung injury and membrane irritation.

3.8 ENVIRONMENTAL PROTECTION AND RECYCLING POLICY

Rammer products contribute to the recycling of materials to help customers achieve their environmental objectives. During the manufacturing, all the necessary precautions are taken to make sure that no harm is done to the environment.

Every effort is made to foresee and minimize the risks that might be associated with the operation and maintenance of Rammer products, and which could pose danger to humans or the environment. We support customers in their efforts to consider environmental protection in their everyday work.

When working with a Rammer product, follow these guidelines:

- Dispose of packaging materials properly. Wood and plastic can be burned or recycled. Deliver the steel belts to a metal recycling center.
- Protect the environment from oil spills.

In case of hydraulic oil leaks, the equipment should be serviced immediately.

Follow the product's greasing instructions and avoid excessive greasing.

Be careful when handling, storing and transporting oils.

Dispose of empty oil or grease containers appropriately.

Consult local authorities for detailed instructions.

- All metal parts of the product can be recycled by delivering them to an authorized scrap metal collection facility.
- Comply with local waste classification rules when disposing of used rubber or plastic parts (buffers, wear plates, seals).
- When scrapping the whole product or pressure accumulator, consult your local Rammer dealer for instructions on depressurizing the accumulator.
- Do not take the product or accumulator to a scrap metal collection center without depressurizing the accumulator first.
- Dispose of batteries in accordance with applicable federal, state and local regulations. As a safety precaution, properly insulate batteries for disposal. Cover both terminals of the battery with tape, wrap the battery in an insulated bag, or pack the battery in its original packaging in order to prevent ignition due to short-circuit.

Consult with your local dealer for more information.

4. SAFETY

4.1 GENERAL SAFETY

All mechanical equipment can be hazardous if operated without due care or correct maintenance. Most accidents involving machine operation and maintenance are caused by failure to observe basic safety rules or precautions. An accident can often be avoided by recognizing potentially hazardous situations before an accident occurs.

Because it is impossible to anticipate every possible circumstance that might involve a potential hazard, the warnings in this guide and on the machine are not all inclusive. If a procedure, tool, working method or operating technique not specifically recommended by manufacturer is used, you must satisfy yourself that it is safe for you and others. You should also ensure that the product will not be damaged or made unsafe by the method of operation or maintenance procedures you choose.

Safety is not just a matter of responding to the warnings. All the time you are working with your attachment you must pay attention to what hazards there might be and how to avoid them. Do not work with the product until you are sure that you control it. Do not start any job until you are sure that you and those around you will be safe.



Warning! Read the following warning messages carefully. They tell you of different hazards and how to avoid them. If proper precautions are not taken you or others could be seriously injured.

4.2 SAFETY INSTRUCTIONS

MANUALS

Study this manual before installing, operating or maintaining the product. If there is anything you don't understand, ask your employer or your local dealer to explain it. Keep this manual clean and in good condition.

The related safety label on the hammer and the text on the label are shown below.

"IGNORING INSTRUCTIONS HAZARD

Faulty handling practice could cause death or severe injury.

Read and follow the instructions in the operator's manual."

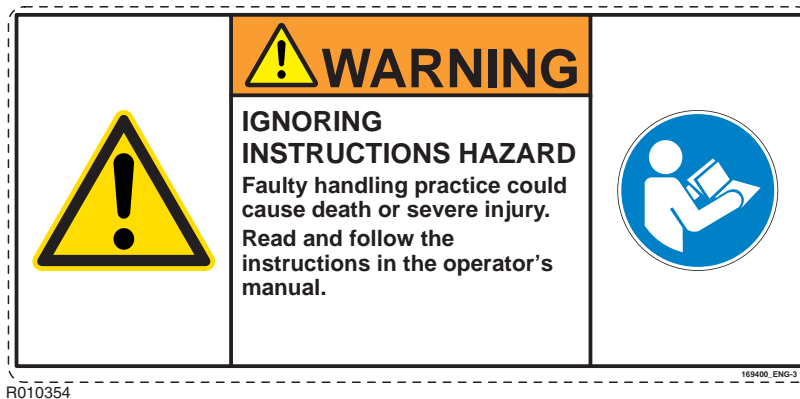

CARE AND ALERTNESS

All the time you are working with the product, take care and stay alert. Always be alert for hazards. The possibility of a serious or even fatal accident is increased when you are intoxicated.

CLOTHING

You can be injured if you do not wear proper clothing. Loose clothing can get caught in the machinery. Wear protective clothing to suit the job.

Examples are: a safety helmet, safety shoes, safety glasses, well-fitting overalls, ear-protectors and industrial gloves. Keep cuffs fastened. Do not wear a necktie or scarf. Keep long hair restrained.

PRACTICE

You and others can be killed or injured if you perform unfamiliar operations without practising them first. Practice away from the job site, in a clear area.

Keep other people away. Do not perform new operations until you are sure you can do them safely.

REGULATIONS AND LAWS

Obey all laws, work site and local regulations which affect you and your equipment.

COMMUNICATIONS

Bad communications can cause accidents. Keep people around you informed of what you will be doing. If you will be working with other people make sure they understand any hand signals you will be using.

Work sites can be noisy. Do not rely only on spoken commands.

WORK SITE

Work sites can be hazardous. Inspect the site before working on it.

Check for potholes, weak ground, hidden rocks and other possible hazards on the ground. Check for utilities (such as electric cables, gas and water pipes). Mark the positions of underground cables and pipes if you will be breaking the ground.

Poor visibility can cause accidents and damage. Make sure that visibility and lighting of the working area are adequate.

BANKS AND TRENCHES

Banked material and trenches can collapse. Do not work too close to banks and trenches where there is a danger of collapse.

SAFETY BARRIERS

Unguarded equipment in public places can be dangerous. Place barriers around the machine to keep people away.

AIRBORNE POLLUTANTS

The related safety label on the hammer and the text on the label are shown below.

"DUST HAZARD

Breathing dust will cause death or severe injury.

Always wear approved respirator."



Airborne pollutants are microscopic particles, which will damage your health, when inhaled. Airborne pollutants on construction sites can be, for example, silica dust, oil fumes or diesel exhaust particles, visible or invisible. Especially in demolition sites, there may be other dangerous substances, such as asbestos or lead paints or other chemical substances.

The effect of airborne pollutants may be immediate if the substance is poisonous. The main danger with airborne pollutants comes from long term exposure, where particles are inhaled but not removed from the lungs. The disease is called silicosis, asbestosis or other, and will result in death or serious injury.

To protect yourself from airborne pollutants, always keep excavator doors and windows closed during operation. Excavators with pressurized cabins should be utilized in hammer operation. Proper maintenance of fresh air filters of the excavator is essential. Where pressurized cabins are not available, proper respirators must be utilized.

Stop working, when bystanders are in the area of airborne pollutants and make sure they have proper respirators. Respirators are as important for bystanders as hard hats.

Respirators for both operator and bystanders must be approved by the respirator manufacturer for the application in question. It is essential that the respirators protect from the tiny dust particles which cause silicosis and which may cause other serious lung diseases. You should not use the equipment until you are sure the respirators are working properly. This means the respirators must be checked to make sure that it is clean, that its filter has been changed, and to otherwise make sure the respirator will protect in the way it is meant to.

Always make sure dust has been cleaned off your boots and clothes when you leave your shift. The smallest particles of dust are the most harmful. They may be so fine that you cannot see them. Remember, you **MUST** protect yourself and bystanders from the danger of breathing or inhaling dust.

Always follow local laws and regulations for airborne pollutants in the working environment.

FLYING CHIPS OF ROCK

The safety label on the hammer is shown below:

"FLYING OBJECTS HAZARD

Fragments fly up to 40 m (130 ft) and could cause death or severe injury.

Stop operation when a person enters hazard zone.

Wear approved personal protective equipment."



Protect yourself and your neighbourhood against flying chips of rock. Do not operate the product or carrier if someone is too close.

The European standard EN 474-1 on safety of earth-moving machinery requires that adequate operator's protection, such as bullet proof glass, mesh guard or an equivalent protection is used.

Keep the cabin windows and doors closed during operation. Window bars are recommended to protect the windows from flying chips of rock.

HIGH NOISE LEVEL

A hammer in operation creates a high noise level. Always wear ear protection to prevent personal injury.

The safety label on the hammer is shown below:

"NOISE HAZARD

Continuous exposure to noise above 80 dB(A) will cause hearing impairment.

Wear approved hearing protectors."

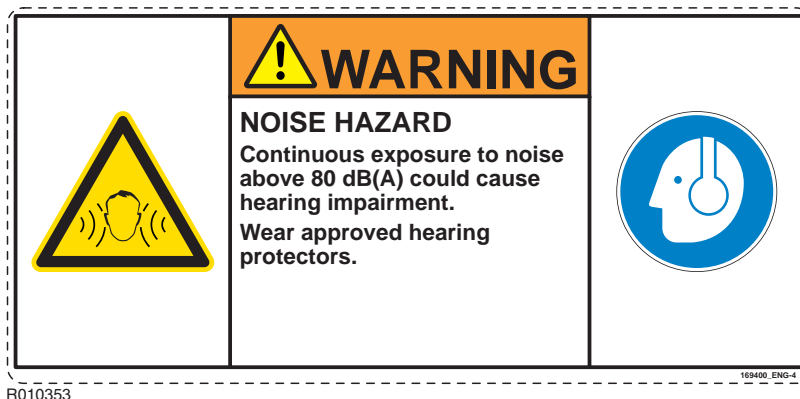

EQUIPMENT LIMITS

Operating the product beyond its design limits can cause damage. It can also be dangerous. See “Hammer specifications” on page 78.

Do not try to enhance the product's performance by unapproved modifications.

HYDRAULIC FLUID

Fine jets of hydraulic fluid at high pressure can penetrate the skin. Do not use your fingers to check for hydraulic fluid leaks. Do not put your face close to suspected leaks. Hold a piece of cardboard close to suspected leaks and then inspect the cardboard for signs of hydraulic fluid. If hydraulic fluid penetrates your skin seek medical help immediately.

Hot hydraulic fluid can cause severe injuries.

HYDRAULIC HOSES AND FITTINGS

Ensure all hydraulic components will withstand maximum pressure and mechanical stresses caused by operation of the attachment. Consult your local dealer for instructions.

FIRE HAZARD

Most hydraulic fluids are flammable and might ignite when contacting hot surface. Avoid spilling hydraulic fluid to hot surfaces.

Working with the product on certain materials can cause sparks and hot splinters to get loose. These can ignite flammable materials around working area.

Ensure that adequate extinguisher is available.

HYDRAULIC PRESSURE

Hydraulic fluid at system pressure can injure you. Before disconnecting or connecting hydraulic hoses, stop the carrier engine, operate the controls to release pressure trapped in the hoses and wait ten (10) minutes. During the operation, keep people away from the hydraulic hoses.

There might be pressurized oil trapped inside the product even if it is disconnected from the carrier. Be aware of possible blank firing while greasing or removing and installing hammer tools. See "Changing the tool" on page 61.

PRESSURE ACCUMULATORS

The safety label on or near the accumulator is shown below.

"HIGH PRESSURE HAZARD

Improper handling of pressurized accumulator will cause death or severe injury.

Read workshop manual before disassembly.

Release pressure before disassembly.

Recharge with nitrogen (N₂) only."



The hammer incorporates one or two pressure accumulators, depending on the model. The accumulators are pressurized even when there is no hydraulic pressure to the hammer. Attempting to dismantle the accumulators without first releasing the pressure can cause injury or death. Do not try to dismantle pressure accumulators, contact your local dealer first.

LIFTING EQUIPMENT

You can be injured if you use faulty lifting equipment. Make sure that lifting equipment is in good condition. Make sure that the lifting equipment complies with all local regulations and is suitable for the job. Make sure that the lifting equipment is strong enough for the job and that you know how to use it.

Do not use this product or any of its parts for lifting. See “Lifting instructions” on page 9. Contact your carrier dealer to find out how to lift with your carrier.

SPARE PARTS

Use only genuine spare parts. Use only genuine tools with hydraulic hammers. The use of other spare part or hammer tool brands may damage the product and void the warranty.

EQUIPMENT CONDITION

Defective equipment can injure you or others. Do not operate equipment which is defective or has missing parts.

Make sure the maintenance procedures in this manual are completed before using the product.

REPAIRS AND MAINTENANCE

Do not try to do repairs or any other maintenance work you do not understand.

MODIFICATIONS AND WELDING

Unapproved modifications can cause injury and damage. Contact your local dealer for advice before modifying the product. Before welding on the product while it is installed on the carrier, disconnect the carrier alternator and battery. Note that welding of the hammer tools will render them useless and make the warranty void. Note that welding on the cast iron parts may cause them to crack or render them useless, and will void the warranty.

METAL SPLINTERS

You can be injured by flying splinters when driving metal pins in and out. Use a soft-faced hammer or drifts to remove and fit metal pins, such as bucket pins. Always wear safety glasses.

LABELS ON THE PRODUCT

Safety labels communicate the following four things:

- The severity level of the risk (that is, signal word "DANGER" or "WARNING").
- The nature of the hazard (such as high pressure, or dust).
- The consequence of interaction with the hazard.
- How to avoid the hazard.

You must ALWAYS follow the instructions of the safety messages and symbols of the product safety labels and the instructions set forth in the manuals to avoid death or severe injury!

Keep the safety labels clean and visible at all times. Check the condition of safety labels daily. Safety labels and instructions which have disappeared, been damaged, painted over, come loose or do not meet the legibility requirements for safe viewing distance, must be replaced before operating the product.

If a safety label is attached to a part that is replaced, install a new safety label on the replacement part. If this manual is available in your language, then the safety labels should be available in the same language.

There are several specific safety labels on this hammer. Please become familiarized with all safety labels. The location of the safety labels is shown in the illustration below.

When you clean the safety labels, use a cloth, water and soap. Do not use solvent, gasoline or other harsh chemicals to clean the safety labels.

Solvents, gasoline or harsh chemicals could loosen the adhesive that secures the safety labels. Loose adhesive will allow the safety label to fall.

Rammer Hydraulic Hammer
 Model: XXXX
 Version: XXXXXXXX
 Serial number: XXXXXXXX
 Hammer weight: XXXX kg
 Min. working weight: XXXX kg
 Operating pressure: XXX-XXX bar
 XX-XX MPa
 Oil flow: XXX-XXX l/min
 Manufactured: XX/XXXX
 Manufacturer:
 Sandvik Mining and Construction Oy
 Tavalkatu 6
 15170 Lahti
 Finland

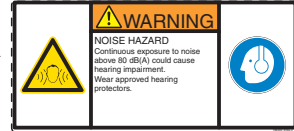
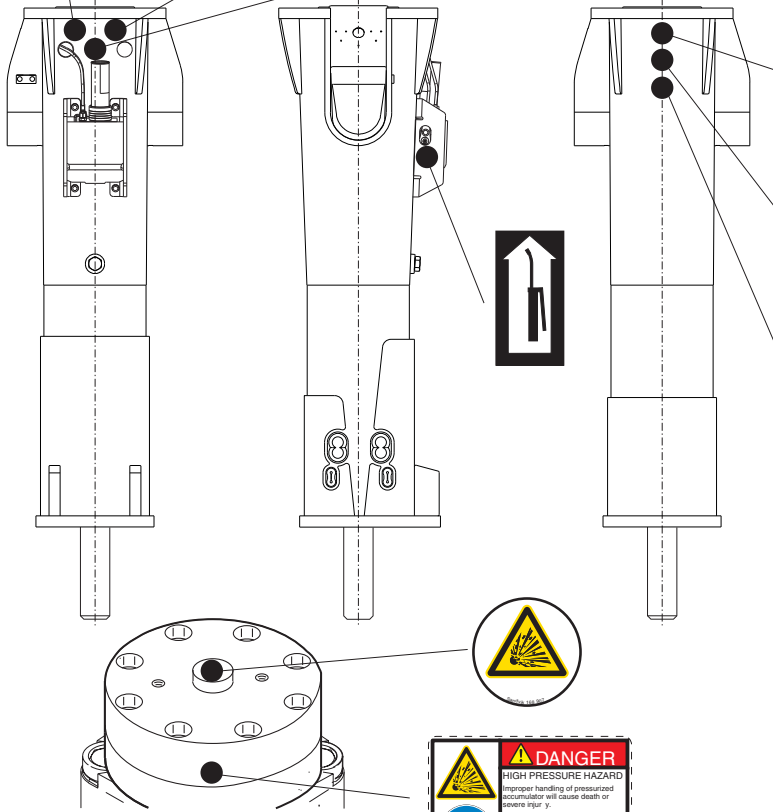

R010502

5. OPERATION

5.1 OPERATING INSTRUCTIONS

RECOMMENDED USE

The hammer is designed to be used in breaking concrete, road surface or asphalt, hard or frozen ground. It can be also used in breaking moderate sized boulders as well as in demolishing reinforced structures and for major excavation and clearing work. Your local dealer will gladly give you more information.

OPERATING CONDITIONS

Principle of installation

Almost all carriers meeting mechanical and hydraulic requirements can be used to operate the attachment. See “Hammer specifications” on page 78. The product is installed on the carrier much in the same manner as installing a bucket or other attachments. A flange mounted attachment requires a separate mounting bracket.

If the carrier has already auxiliary hydraulic circuit, the installation requires only suitable hoses and fittings. If the carrier does not have suitable kit to run the attachment, one must be built. This may require installation including new piping and additional valves such as directional valve and pressure relief valve.

Suitable kits can be ordered from the local dealers, from carrier manufacturers and their dealers or from third party suppliers.

Hydraulic oil

In general the hydraulic oil originally intended for the carrier can be used with this product. See “Requirements for hydraulic oil” on page 52.

Operating temperature

The operating temperature is -20 °C (-4 °F) to 80 °C (176 °F). If the temperature is lower than -20 °C (-4 °F), the hammer and tool have to be preheated before any operations can begin, in order to avoid breaking the accumulator's membrane and the tool. During operation they will remain warm. See “Preheating the hammer” on page 31.

Note: The temperature of the hydraulic oil must be monitored. Ensure that oil grade and monitored oil temperature together guarantee correct oil viscosity. See “Oil specifications” on page 53.

Noise dampening

Operating the hammer near residential areas or other noise sensitive areas can cause noise pollution. In order to avoid unnecessary noise, please follow these basic rules:

1. When operating the hammer, keep the tool at a 90 degree angle to the material and the feed force in-line with the tool.
2. Replace or fix all parts that are worn out, damaged or loosened. This not only saves your hammer but it also decreases the noise level.

PRINCIPLES OF BREAKING

To increase the hammer's working life, pay particular attention to correct working methods and how to choose the correct tool for the job. There are essentially two ways of breaking with a hydraulic hammer.

Penetrative breaking (or cutting)

In this form of breaking a moil point or chisel tool is forced inside the material. This method is most effective in soft, layered or plastic, low abrasive material. The high impact rate of the small hammers makes them ideal for penetrative breaking.

Impact breaking

With impact breaking, the material is broken by transferring very strong mechanical stress waves from the tool into the material. Impact breaking is most effective in hard, brittle and very abrasive materials. The high impact energy of the big hammers makes them ideal for impact breaking. The best possible energy transfer between the tool and the object is achieved with a blunt tool. The use of a chisel tool in hard material will cause the sharp edge to wear very quickly.

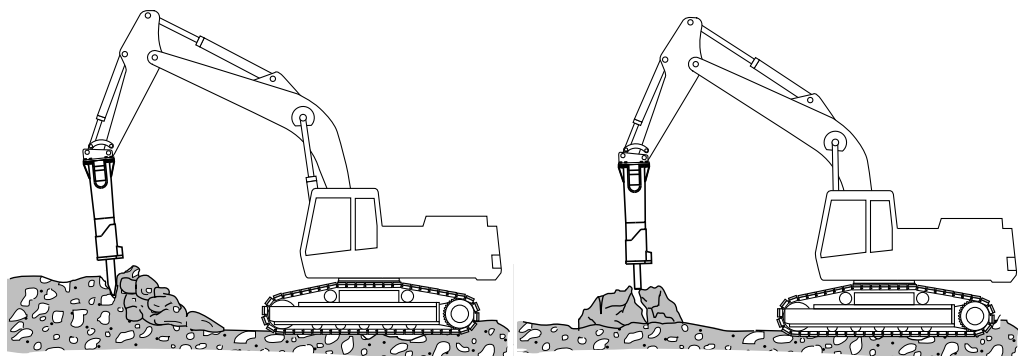

CHOOSING TOOLS

A selection of standard and special tools to suit each application are available. The correct type of tool must be selected to get the best possible working results and longest life time for the tool. Choosing the best tool type for an application may require some testing, please consult with your local dealer. See “Tool specifications” on page 81.

Chisel, moil point and pyramid

- For sedimentary (e.g. sandstone) and weak metamorphic rock into which the tool penetrates.
- Concrete.
- Trenching and benching.

Blunt tool

- For igneous (e.g. granite) and tough metamorphic rock (e.g. gneiss) into which the tool doesn't penetrate.
- Concrete.
- Breaking boulders.

It is important to choose a tool, which is suitable for your hammer and for the application you are working on. The tool selection available depend on hammer model. See “Tool specifications” on page 81.

IDLE BLOW PROTECTION

The hammer includes Idle Blow Protection as a standard feature to prevent idle strokes. Frequent idle strokes have a deteriorating effect on the hammer. Idle Blow Protection can be turned on or off by the operator.

Idle Blow Protection can also be used to warm up the hammer and oil before operation. See “Operating conditions” on page 27. See “Requirements for hydraulic oil” on page 52.

Idle Blow Protection ON (factory setting)

It is recommended that you keep Idle Blow Protection on during normal hammer work. In the ON position, Idle Blow Protection is activated to prevent idle strokes. See illustration 1.

Note: When Idle Blow Protection is on, the hammer can be started only after pressing the tool against an object.

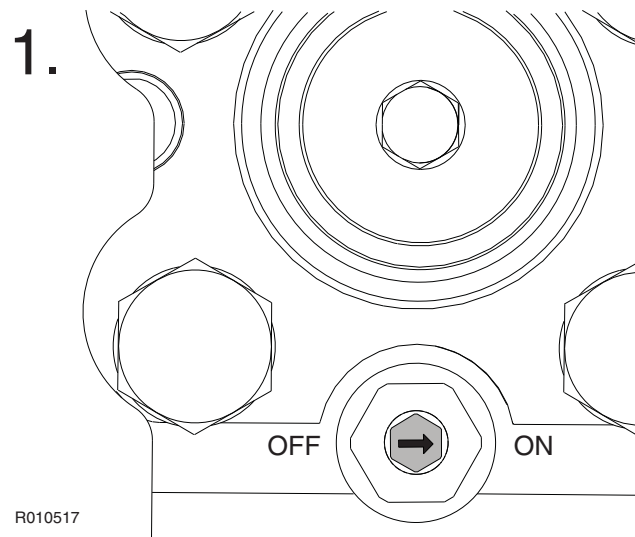
***Idle Blow Protection OFF***

Idle Blow Protection can be turned off when breaking very soft material or in a demolition application where it is difficult to apply enough feeding force. See illustration 2.

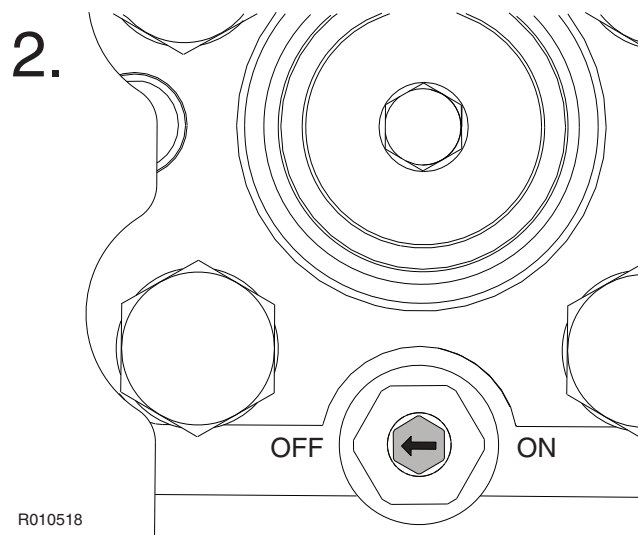

TURNING IDLE BLOW PROTECTION ON AND OFF

1. Remove the shield plate.

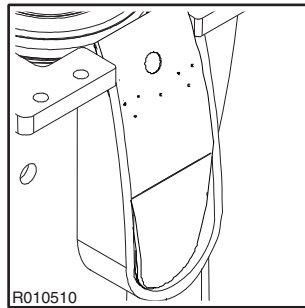

2. To turn Idle Blow Protection on, turn the valve clockwise with a hexagon wrench so that the arrow points to ON. To turn it off, turn to valve counterclockwise so that the arrow points to OFF.

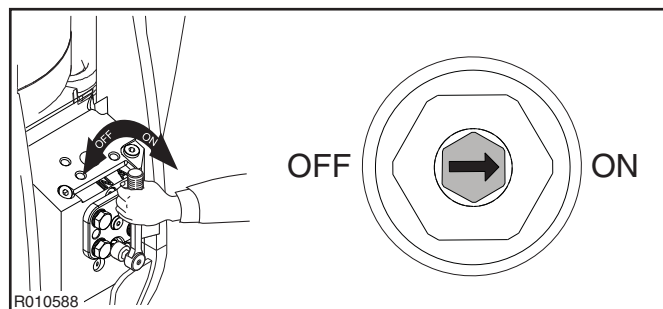

3. Insert the shield plate.

Note: Idle Blow Protection has only two positions, ON and OFF. Do not apply any other positions in between.

PREHEATING THE HAMMER

If the ambient temperature is lower than 0 °C (32 °F), it is recommended that you preheat the hammer according to these instructions:

1. Ensure that the Idle Blow Protection is turned ON.
2. Lift the hammer off the ground.

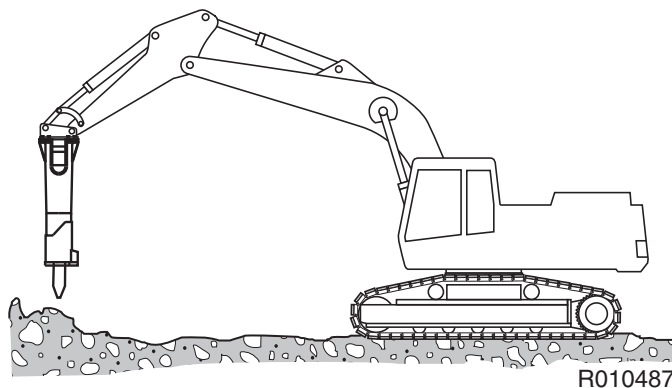

3. Press the hammer operating switch and drive oil through the hammer for a couple of minutes.

5.2 DAILY OPERATION

GENERAL GUIDELINES

- A safety screen is recommended to protect the operator from flying debris. Keep the cabin windows and doors closed during operation.

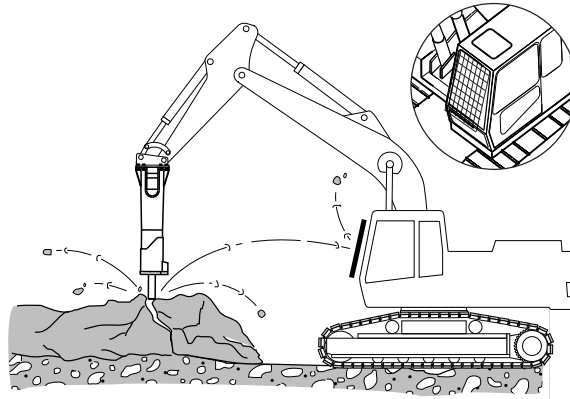

R010013

- Keep the tool at a 90 degree angle at all times. If the object moves or its surface breaks, correct the angle immediately. Keep the feed force and tool aligned.
- Keep the tool shank well greased during operation. Regular visual inspections during operation are recommended. An unlubricated tool shank requires more frequent greasing intervals. A tool shank covered with excessive grease requires less frequent greasing intervals.

R010023

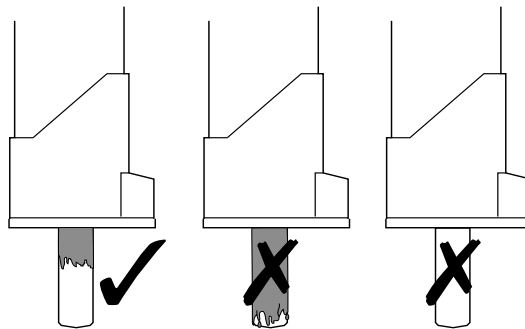

- To use the hammer most efficiently when breaking large objects, concentrate on small steps from the outer edge towards the middle.

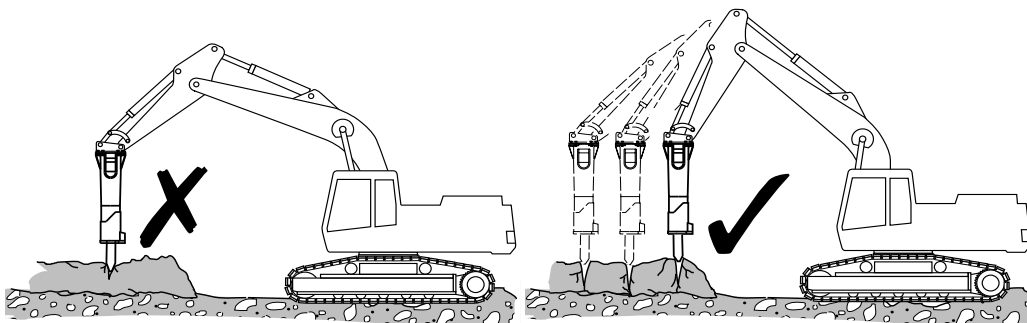

R010015

- Do not strike in one spot for more than 15 seconds at a time. If the object does not break, or if the tool does not penetrate, stop the hammer and change the position of the tool. Working too long in one spot will create stone dust under the tool. Dust dampens the impact effect and produces heat.

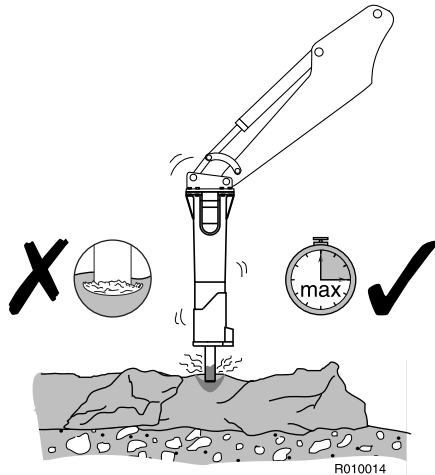

- Do not let the tool move outwards from the hammer when it penetrates. Keep the down-pressure on the hammer while breaking.
- Listen to the hammer's sound when you are using it. If the sound becomes weaker and the impact less efficient, the tool is misaligned with the material and/or there is not enough down force on the tool. Realign the tool and press the tool firmly against the material.
- When demolishing vertical structures (such as brick walls), place the tool against the wall at a 90 degree angle.

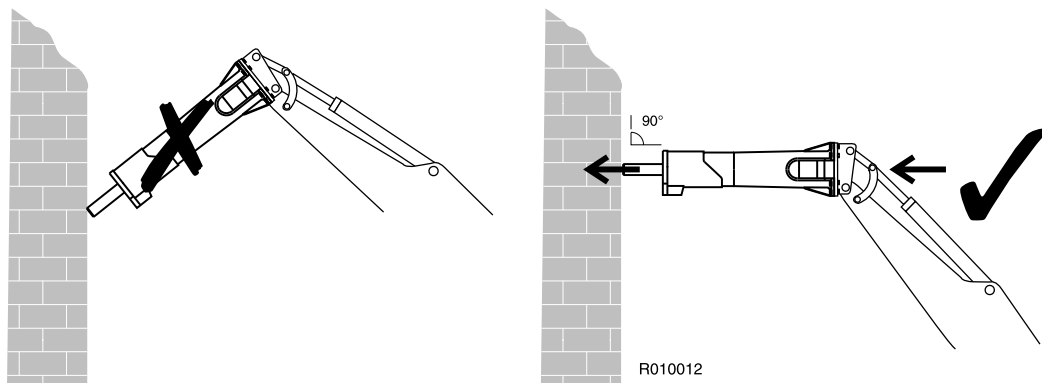

- When breaking concrete, hard or frozen ground, never strike and pry with the tool at the same time. The tool may break. Bending may be caused by stones inside hard or frozen ground. Be careful and stop striking if you find sudden resistance under the tool.

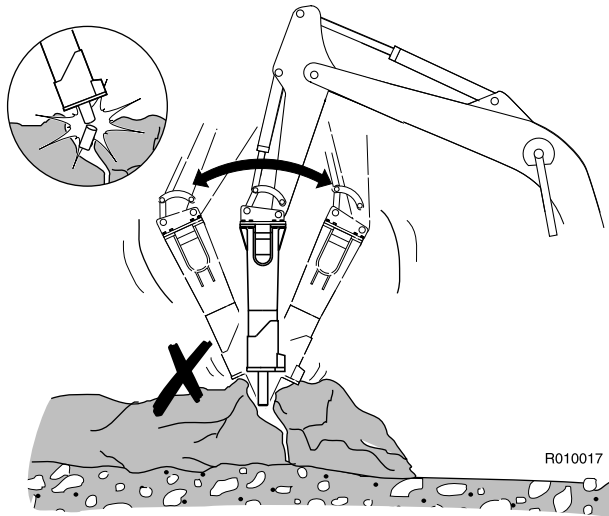

- When breaking hard or frozen ground, use the benching method. Start with clearing a small area from the edge. Then continue by breaking material towards the open area.
- Do not use the hammer tools to move rocks. The stone claws are designed for this purposes.

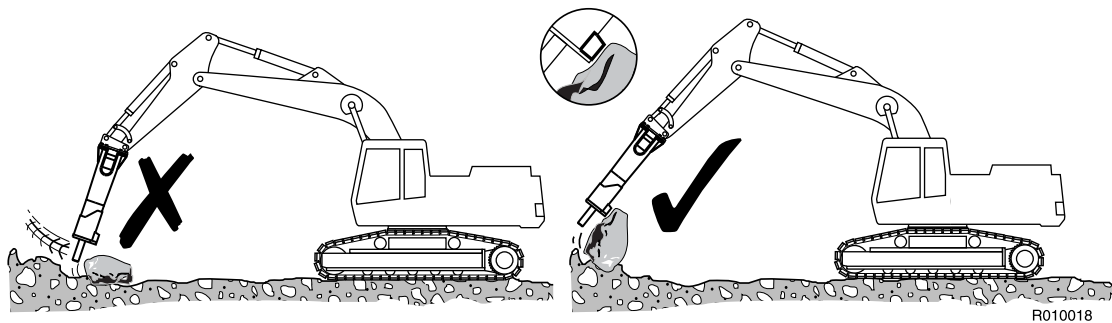

- Do not use the hammer to sweep the ground of debris. This may damage the hammer and the housing will wear out more quickly.

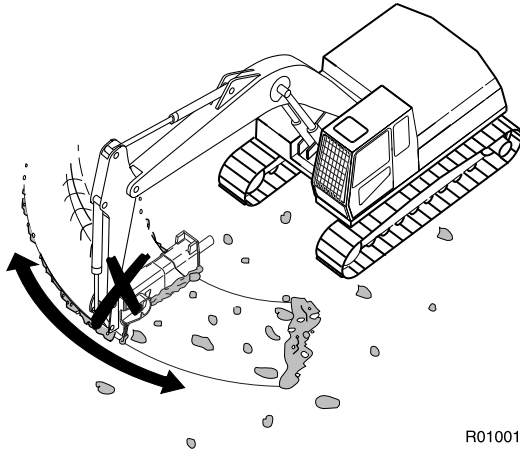

- When operating the hammer, make sure that it does not make contact with the carrier boom or hydraulic lines.

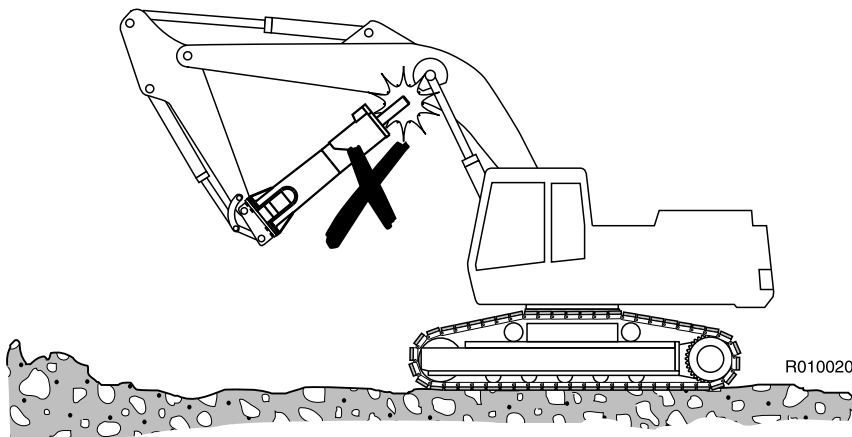

- Do not operate the hammer with the carrier's boom, stick or bucket cylinders at the end of their stroke (either fully extended or fully retracted). Damage to the carrier may result.

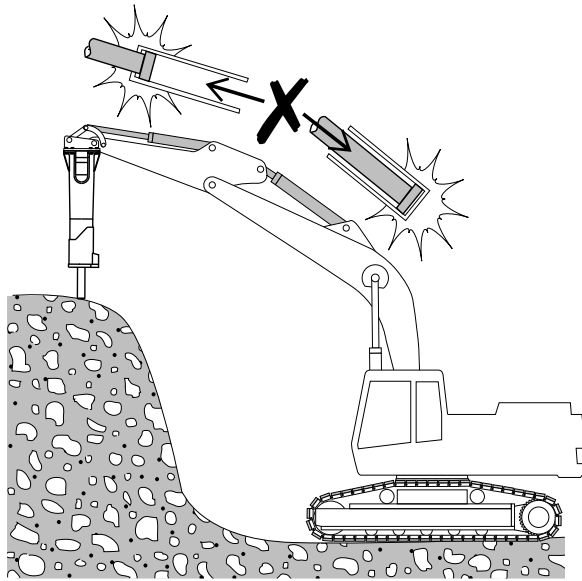

R010021

- Do not use the hammer or hammer tools for lifting. Lifting eyes on the hammer are for storage and maintenance purposes only.

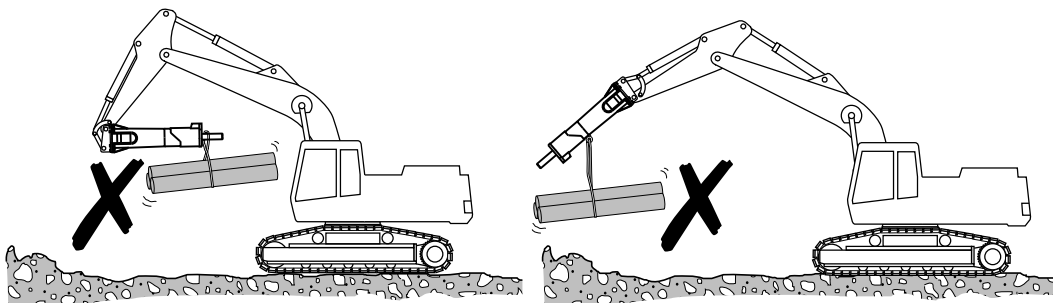

R010022

WORKING PROCEDURE

Warning! Protect yourself and your neighbourhood against flying chips of rock. Do not operate the hammer or carrier if someone is too close to the hammer.

Do not use the hammer, as a standard assembly, under water. If water fills the space where the piston strikes the tool, this generates a strong pressure wave that may damage the hammer.

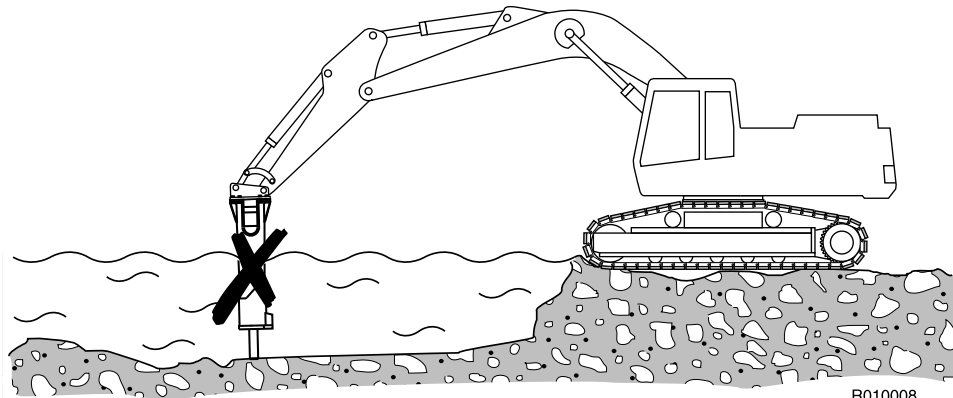

Warning! To avoid falling objects, do not use the product to lift other products. The lifting eyes located on the product housing are to be used solely to lift or handle the product itself. See “Lifting instructions” on page 9.

1. Prepare the carrier for normal excavation work. Move the carrier to the required position. Set the drive to neutral.
2. Set the engine speed to the recommended engine RPM for correct amount of oil supply.
3. Carefully operate the carrier controls to place the hammer and boom into the breaking position. Quick and careless boom movements can result in damage to the hammer.

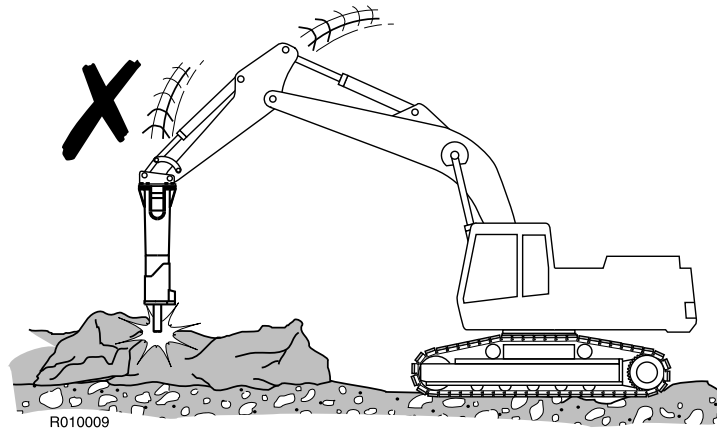

4. Use the excavator boom to press the hammer firmly against the object. Do not pry the hammer with the boom. Do not press too hard or too gently with the boom. The correct force is applied, when the tracks start to lift slightly from the ground.

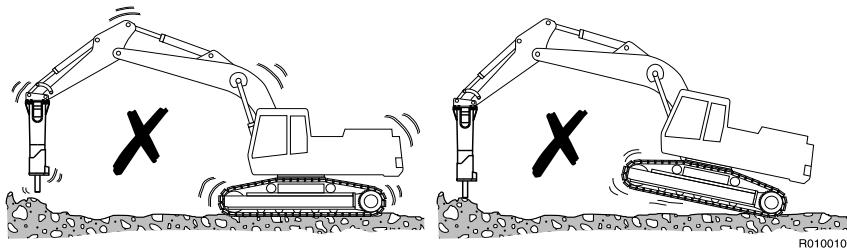
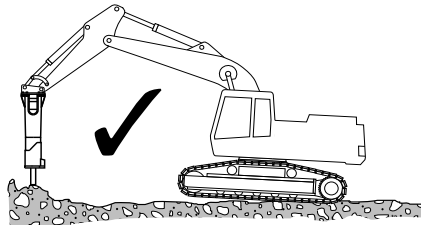

5. Place the tool against the object at a 90 degree angle. Avoid small irregularities on the object which will break easily and cause either idle strokes or an incorrect working angle.

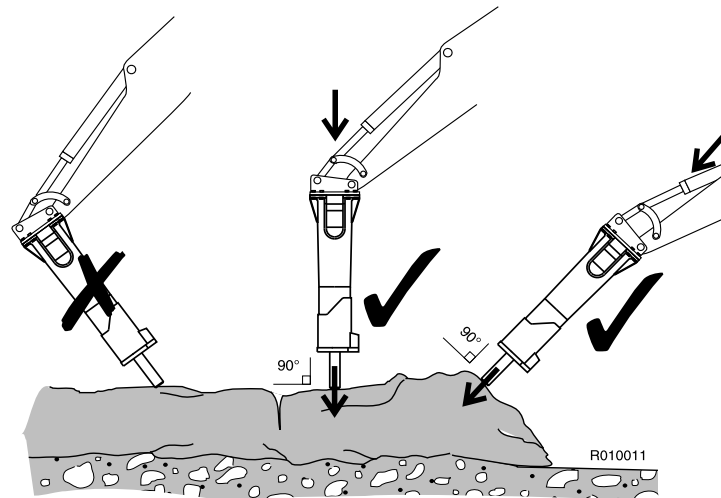

6. Start the hammer.

7. Stop the hammer quickly. Do not allow the hammer to fall down and make idle strokes when an object breaks. Frequent idle strokes have a deteriorating effect on the hammer. If the hammer falls through, the housing wears out more quickly.

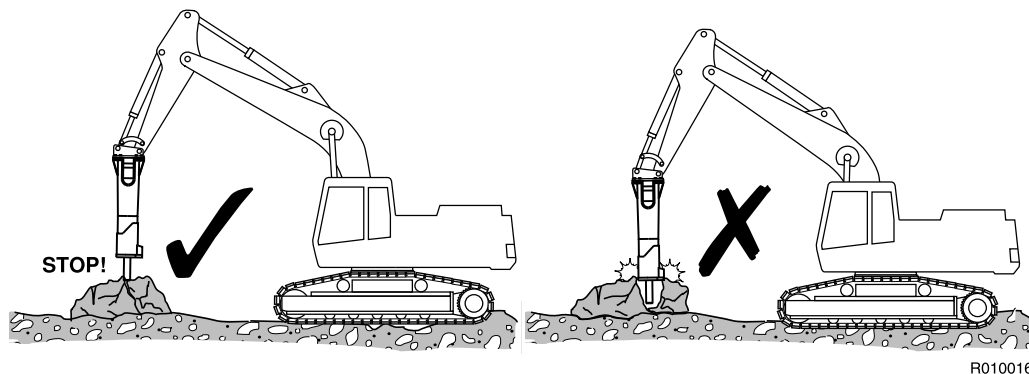

5.3 MOUNTING AND DISMOUNTING THE HAMMER

REMOVAL FROM CARRIER



Warning! The hammer must be secured from rolling over when disconnecting from the carrier. Only use a skilled operator to position the carrier for hammer removal!

Warning! Hydraulic pressure inside the hammer must always be released before opening hose connections!

Warning! Hot hydraulic fluid can cause severe injuries!

1. Position hammer horizontally on the floor. If the hammer is going to service, remove the tool.
2. Stop the carrier engine. Operate boom and hammer controls to release pressure trapped inside hoses. Wait ten minutes for oil pressure to drop.
3. Close hammer inlet and outlet lines. If quick couplers are used, disconnection automatically closes hammer lines. If hammer line includes ball valves, please make sure that they are closed.
4. Disconnect hoses. **NOTICE! Protect environment from oil spills.** Plug the hoses and the hammer inlet and outlet ports to keep dirt out from hydraulic circuit.
5. Remove bucket pins and other parts.

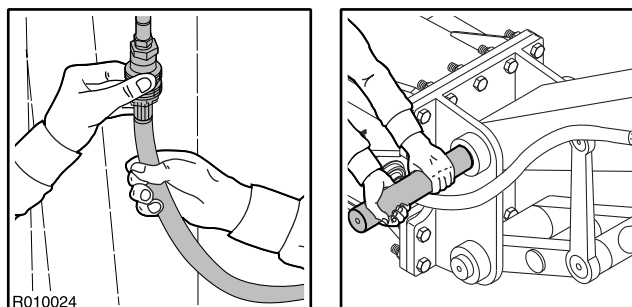

6. The carrier can be moved aside.

INSTALLATION

1. Install hammer in the same manner as mounting a bucket. Install bucket pins.
2. Connect hoses. Hammer inlet port is marked on the valve body with "IN" and outlet port with "OUT". An installation inspection must be carried out after the product has been mounted on the carrier. In the installation inspection certain specifications (such as operating pressure, oil flow) are checked so that they are within given limits. See "Hammer specifications" on page 78.
3. Open hammer inlet and outlet lines.

5.4 MOVEMENT

The transportation and parking positions are shown below. When moving with the hammer, ensure that it isn't too close and doesn't point at the cabin window.

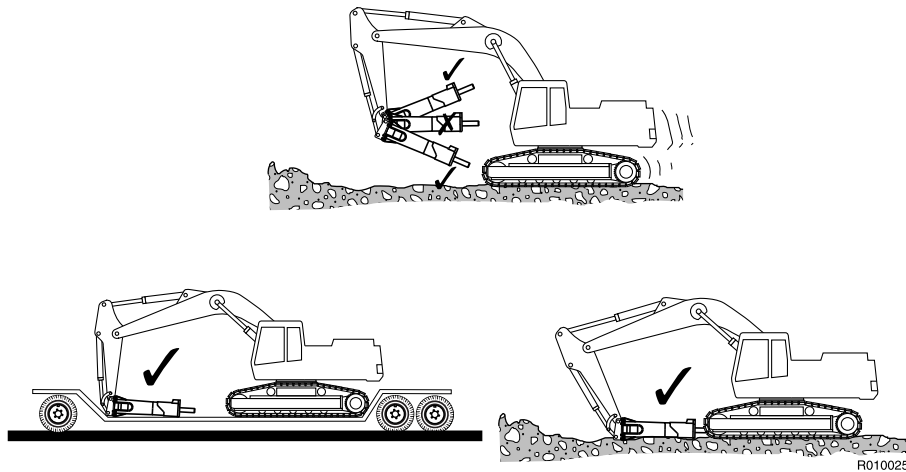

5.5 SPECIAL CONDITIONS OF USE

Special conditions of use are conditions in which the hammer is used for some work other than normal breaking or demolition, such as:

- Tunneling
- Scaling
- Foundry cleaning
- Underwater operations
- Operations in extremely low or high temperatures
- Use of special hydraulic fluids
- Hammer operations with a special carrier (e.g., an extra long boom)
- Other special conditions

Special conditions of use may require modifications to the attachment, special operating techniques, increased maintenance or special wear items. If you are planning to use the hammer under a special condition of use, please consult your local dealer for instructions.

UNDERWATER OPERATION



Use environmentally friendly oil and tool grease when you are using the hammer under water.



Warning! If you are using the hammer under water, protect yourself and your surroundings against compressed water/air spray and possible broken compressed air hoses.

Warning! If you are using the hammer under water, check the stability of the carrier and the hammer. Water gets inside the hammer, causing it to weigh more. Due to the added water weight, lift the hammer carefully out of the water.

The hammer as a standard assembly, must not be used under water. If water fills the space where the piston strikes the tool, a strong pressure wave is generated and the hammer may be damaged.

The latest hammer models can be modified for underwater operations for only short periods. The operating principle in underwater hammering is to conduct pressurized air through a built-in channel to the spaces above and below the piston. The air pressure prevents water entering the hammer. The hammer as a standard assembly, must not be used under water. If water fills the space where the piston strikes the tool, a strong pressure wave is generated and the hammer may be damaged.

The wear resistance of the hammer parts is considerably lower under water than in normal use. This is caused by corrosion and by the abrasive effect of mud in water. After starting underwater hammering, the hammer must be inspected regularly, for example after every half hour operation. Adapt the inspection intervals to the working conditions. See “Maintenance intervals in underwater use” on page 60.

In underwater applications, the productivity of a hydraulic hammer is considerably lower than in normal work. This is caused by:

1. The breaking object is not visible to the operator. This causes misalignment between the tool and the object and unnecessary idle strokes.
2. The hammer must be inspected and greased more often than in normal situations.
3. **The hammer must always be completely serviced after working on underwater job sites.**

5.6 STORAGE

LONG TERM STORAGE

Observe the following points when the hammer is stored. In this way the vital parts of the attachment are protected from rust and the machine is ready to be used whenever necessary.

1. The storage area must be dry.
2. The tool must be removed in hydraulic hammers.
3. The lower end of the piston, tool and tool bushings must be well protected with grease in all hydraulic hammers.
4. Connections must be sealed with clean plugs to prevent oil leakage and dirt from getting into couplings.
5. The product must be stored in the vertical position.
6. Make sure the product cannot fall.

LUBRICATION

1. HAMMER TOOL GREASING

1.1 RECOMMENDED GREASES

For tool lubrication use only RAMMER SPECIAL TOOL GREASE, part no. 902045 (400 g cartridge), part no. 902046 (18 kg drum), or any grease that meets the following criteria:

- No dropping point or very high, over 250 °C (480 °F).
- Maximum service temperature at least 150 °C (300 °F).
- Minimum working temperature below lowest ambient temperature.
- Additives: molybdenum disulfide (MoS₂), graphite or equivalent.
- Penetration 0 ... 2 (NLGI).
- No reaction with hydraulic oils.
- Water resistant.
- Good adhesion with steel.

AUTOMATIC GREASING

- RAMMER GREASE CARTRIDGE, part no. 951370



Wear gloves when handling the grease containers. If you get grease onto your skin, wash it away with soap and water.

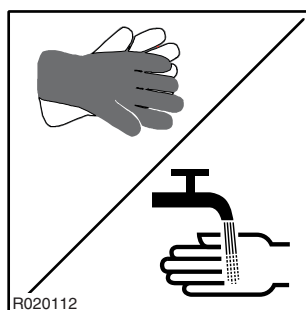

1.2 AUTOMATIC GREASING



Dispose of empty grease containers appropriately.

The hammer can be equipped with an automatic greasing device. See “Greasing device” on page 14.

Do not remove the grease cartridge unnecessarily. Always keep the grease cartridge in the greasing device to prevent dirt from entering the greasing device.

Note: Some hammer models are equipped with an adapter kit for manual greasing and do not include an automatic greasing device.

REPLACING THE GREASE CARTRIDGE

Measure the distance from the top of the grease cartridge. Replace the grease cartridge if the distance is more than 200 mm (7.87 in). The grease cartridge is empty and has to be replaced when the distance is 210 mm (8.27 in).

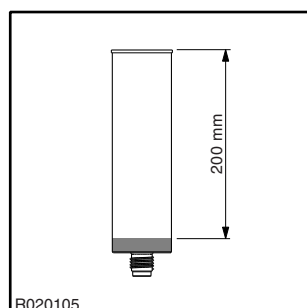

1. Unscrew and remove the grease cartridge.
2. Dispose of the used cartridge appropriately. Note: The grease cartridge is disposable; it cannot be refilled.
3. Check and clean the grease cartridge seat in the cartridge holder. Remove the old grease cartridge seal.
4. Remove the protective cap from the new cartridge.

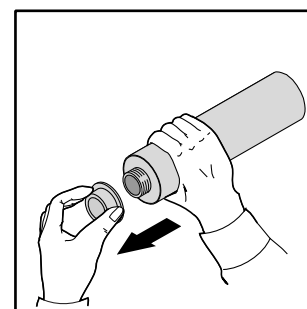
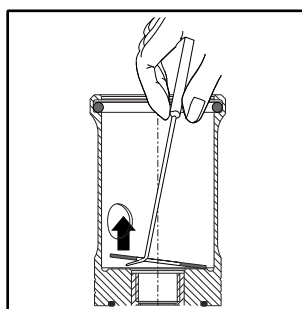
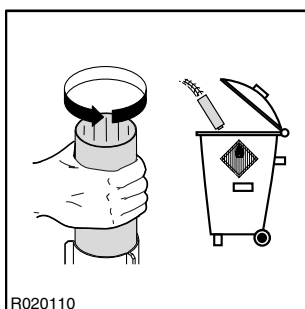

5. Check the grease cartridge seal.

6. Push the cartridge piston with fingers until approximately 15 mm of grease comes out.

7. Insert the cartridge and tighten it.

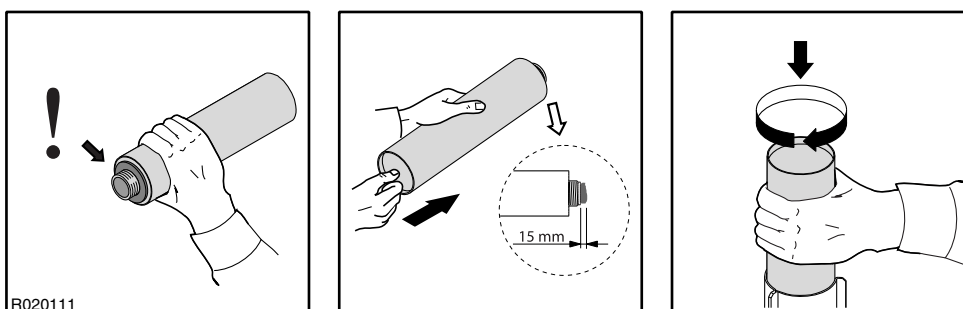

1.3 ADJUSTING THE DOSE

Note: Some hammer models are equipped with an adapter kit for manual greasing and do not include an automatic greasing device.

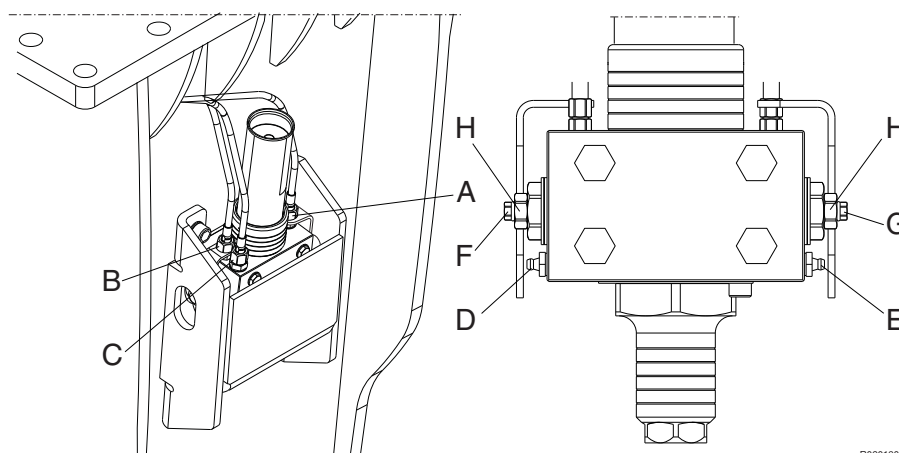

- A. Grease hose to upper tool bushing
- B. Grease hose to lower tool bushing
- C. Pressure hose
- D. Grease nipple for manual greasing to lower tool bushing
- E. Grease nipple for manual greasing to upper tool bushing
- F. Adjusting screw for grease dosage to lower tool bushing
- G. Adjusting screw for grease dosage to upper tool bushing
- H. Locking nut for the adjusting screw

ADJUSTING THE DOSE

Please note that the actual amount of grease needed for proper lubrication varies according to:

- hammer size
- application: the amount of grease depends on the number of working cycles within a given time. In practice this means that, in an application where the working cycles are short but the quantity is high, a smaller dose can be used.
- wear rate of the tool shank and bushing
- condition of the tool seal
- operators working techniques
- grease quality

1. Turn the locking plate and plug aside.

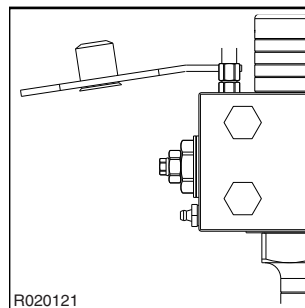

2. Open the locking nut.

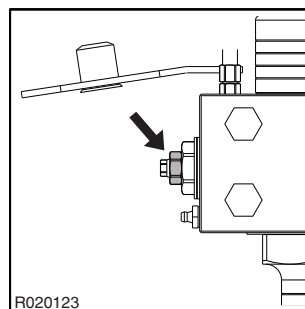

3. Turn the adjusting screw for grease dosage clockwise to close it completely.

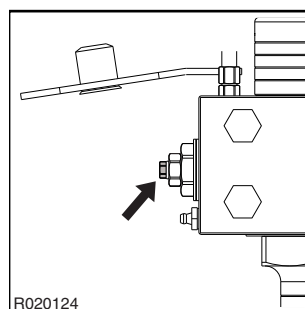

4. Next open the adjusting screw for grease dosage by turning it counter-clockwise as needed. See table below.

5. Tighten the locking nut to the specified torque setting. See table below.
6. Turn the locking plate and plug to the correct positions.

| Item | Specification/Torque |
|-----------------------------|--|
| Shield screws | 175 Nm (129 lbf ft) |
| Adjusting screw locking nut | 50 Nm (37 lbf ft) |
| Adjusting range | Linear 0 ... 7 turns (7 mm) |
| Basic adjustment | 4 turns open / means 0.25 g grease/ impact period |
| 1-turn adjustment | 0.053 g grease/impact period |

1.4 MANUAL GREASING



Follow the product's greasing instructions and avoid excessive greasing. Dispose of empty grease containers appropriately.

Manual greasing is always possible even if the hammer is equipped with the automatic greasing device. Manual greasing is necessary if there is no grease available for the greasing device, greasing device has malfunction or pressure hose is damaged. Check also the grease hose conditions inside the housing.

GREASING INTERVAL

1. Tool shank must be well lubricated before installing tool.
2. 5-10 strokes from grease gun to tool bushings and tool at regular intervals.
3. Adapt interval and amount of grease to wear rate of tool and working conditions. This can be anything between two hours and daily, depending on material (rock/concrete) to be broken. See "Recommended greases" on page 46.

Insufficient greasing or improper grease may cause:

- Abnormal wear of tool bushing and tool
- Tool breakage

CORRECT GREASING

1. Position the hammer standing upright resting on the tool on firm surface.
2. Stop carrier engine and wait 10 minutes for oil pressure to drop inside hammer.
3. Apply tool grease from grease gun to greasing points marked with the following sticker.

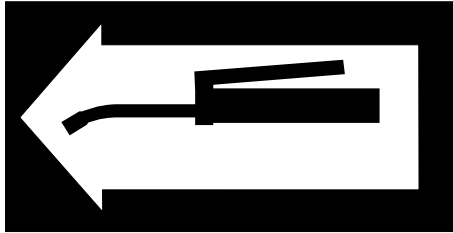

R020002

Note: The hammer must stand upright resting on the tool to ensure that the grease will penetrate downwards between the tool and the bushing.

Do not fill the space between the piston and the tool with grease. A lower piston seal failure can result and the hammer will subsequently leak oil.

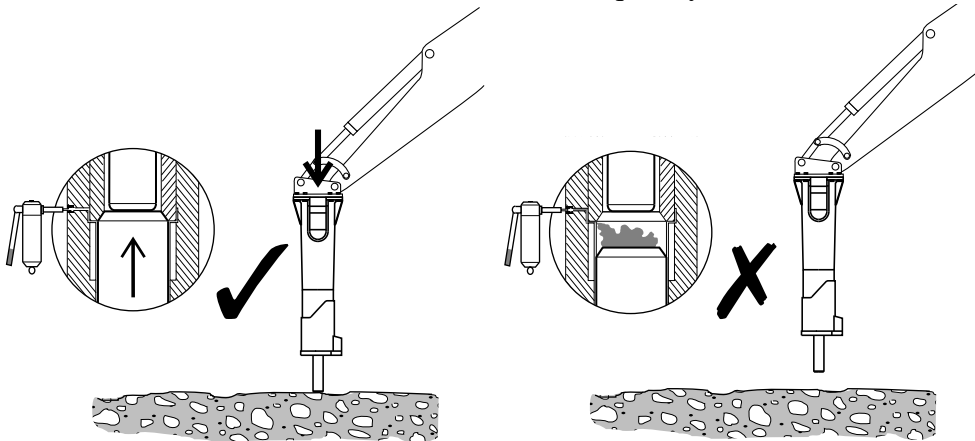

R020001

2. CARRIER HYDRAULIC OIL

2.1 REQUIREMENTS FOR HYDRAULIC OIL

GENERAL REQUIREMENTS

In general the hydraulic oil originally intended for the carrier can be used with this product. However, since working with the product heats the oil more than the usual excavation work, the temperature of the oil must be monitored.

If the temperature of the hydraulic oil exceeds 80 °C (176 °F), an auxiliary oil cooler is needed. The oil viscosity must be between 20-1000 cSt while the attachment is being used.

When the product is used continuously, the temperature of the hydraulic oil normalizes at a certain level depending on conditions and on the carrier. The temperature in the tank must not exceed the maximum allowed.

The hammer must not be started if the ambient temperature is below freezing and the oil is very thick. The machine must be moved to bring the oil temperature above 0 °C (32 °F) before hammering can start (viscosity 1000 cSt or 131 °E).

OIL SPECIFICATIONS

Table below shows hydraulic oils recommended for hammer use. The most suitable oil is selected in such a way that the temperature of the hydraulic oil in continuous use is in the ideal area on the chart and the hydraulic system is used to best advantage.

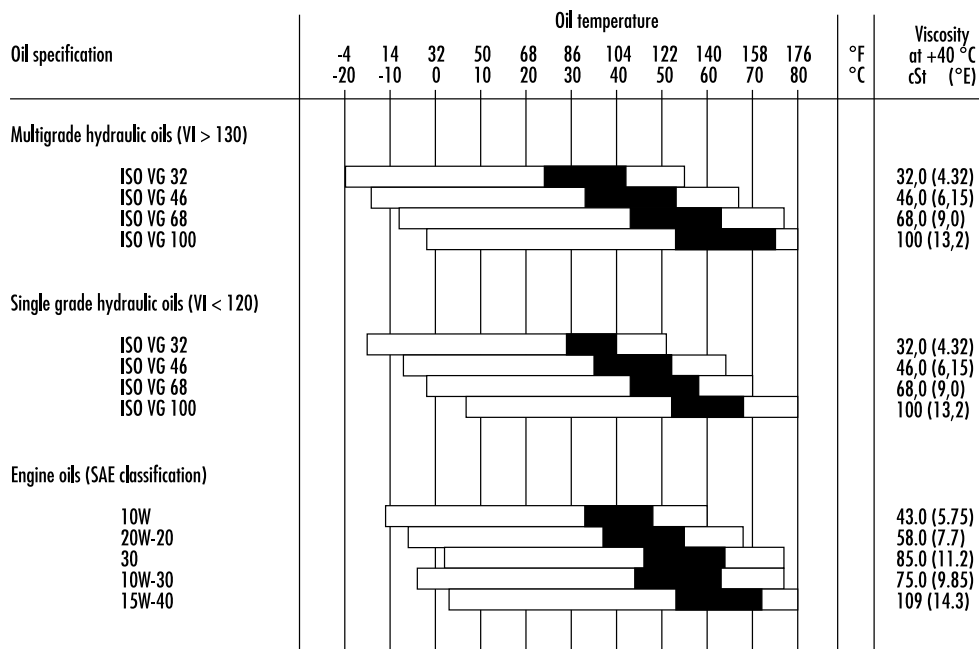

VI = Viscosity index
 □ Permitted oil temperature
 ■ Recommended oil temperature

R020004

Oil too thick

- Difficult start up
- Stiff operation
- Hammer strikes slowly
- Danger of cavitation in pumps and in the hydraulic hammer
- Sticky valves
- Filter bypass opens, impurities in the oil are not removed

Oil too thin

- Efficiency losses (internal leaks)
- Damage to gaskets and seals, leaks
- Accelerated wearing of parts, because of decreased lubrication efficiency
- Hammer strikes irregularly and slowly
- Danger of cavitation in pumps and in the hydraulic hammer

Note: We strongly recommend the use of different hydraulic oils in the summer and in the winter if there is an average temperature difference of more than 35 °C (63 °F). The correct hydraulic oil viscosity is thus ensured.

SPECIAL OILS

In some cases special oils (for example biological oils and non-inflammable oils) can be used with hydraulic hammers. Observe the following aspects when considering the use of special oils:

- The viscosity range in the special oil must be in the given range (20-1000 cSt)
- The lubrication properties must be sufficient
- The corrosion resistance properties must be good enough

Note: Although a special oil could be used in the carrier, always check its suitability with the hammer due to high piston speed of the hammer. Contact the oil manufacturer or your local dealer for more information about special oils.

2.2 OIL COOLER

The correct place to connect the hammer return line is between the oil cooler and the main filters. The hammer return line should not be connected before the oil cooler. Routing the hammer return flow through the cooler, might damage either the cooler, due to pulsating flow, or the hammer, due to increased back pressure.

The carrier hydraulic system must be able to maintain the temperature within an acceptable level during the hammer operation. This is for two reasons.

1. Seals, wipers, membranes and other parts manufactured from the corresponding materials can normally stand temperatures up to 80 °C (176 °F).
2. The higher the temperature is, the less viscous the oil gets thus losing its capability to lubricate.

A standard carrier, with a proper hammer circuit, meets the requirements of the necessary cooling capacity. If the oil temperature tends to be too high during the hammer operation, the following things must be checked:

- The hammer circuit pressure relief valve is not open when the hammer is operated.
- The hammer circuit pressure drops are reasonable. Less than 10 bar (145 psi) in the pressure line and less than 5 bar (75 psi) in the return line.
- Hydraulic pumps, valves, cylinders, motors etc. and hammer do not have internal leakages.

If all of the above mentioned things are in order, and the temperature of the hydraulic oil still tends to be too high, extra cooling capacity is needed. Consult the carrier manufacturer or dealer for details.

2.3 OIL FILTER

The purpose of the oil filter is to remove impurities from the hydraulic oil. Air and water are also impurities in oil. Not all impurities can be seen with the naked eye.

Impurities enter the hydraulic system:

- During hydraulic oil changes and refilling.
- When components are repaired or serviced.
- When the hammer is being installed on the carrier.
- Because of component wear.

Normally the existing main oil filters of the carrier are used as hammer circuit return line filters. Consult the carrier manufacturer or your local dealer concerning instructions for the filter change intervals.

In hydraulic hammer work the carrier oil filter must fulfil the following specifications:

- The oil filter must allow maximum particle size of 25 microns (0.025 mm).
- The oil filter material must be artificial fibre cloth or very fine gauge metallic mesh to withstand pressure fluctuations.
- The oil filter must have a nominal flow capacity of at least twice the hammer's maximum flow.

In general, oil companies guarantee new oils to have a particle count of 40 microns maximum. Filter the oil when filling the tank.

The damage caused by hydraulic oil impurities in the carrier and hammer circuits:

1. The working life of the pumps and other components is significantly shortened.
 - Rapid wear of parts.
 - Cavitation.
2. Wear of cylinder and gaskets.
3. Reduced hammer efficiency.
 - Accelerated wear of moving parts and seals.
 - Danger of piston seizing up.
 - Oil leakages.
4. Shortened working life and reduced lubricating capability of oil.
 - Oil overheats.
 - Oil quality deteriorates.
 - Electro-chemical changes in hydraulic oil.

5. Valves do not function properly.

- Spools bind.
- Rapid wear of parts.
- Blocking of small holes.

Note: Component damage is only a symptom. The trouble itself will not be cured by removing the symptom. After any component damage due to impurities in the oil, the entire hydraulic system has to be cleaned. Dismantle, clean and reassemble the hammer and change the hydraulic oil.

MAINTENANCE

1. ROUTINE MAINTENANCE

1.1 OVERVIEW

This product is a precision-made hydraulic machine. Therefore, great care and cleanliness should be taken when handling any of the hydraulic components. Dirt is the worst enemy in hydraulic systems.

Handle the parts carefully and remember to cover any cleaned and dried parts with clean lint-free cloth. Do not use anything other than purpose-designed materials for cleaning hydraulic parts. Never use water, paint thinners or carbon tetrachloride.

Components, gaskets and seals in the hydraulic system should be oiled with clean hydraulic oil before assembly.

1.2 INSPECTION AND MAINTENANCE BY THE OPERATOR

Note: Time intervals in carrier hours refer to the length of time that the carrier is operating with the hammer attached.

EVERY TWO CARRIER HOURS

- Check that the grease cartridge is not empty. Replace if necessary.
- Check that the tool has received sufficient grease.
- Grease manually if the automatic greasing device is not in use. See “Manual greasing” on page 50.
- Observe hydraulic oil temperature, all lines and connections as well as impact efficiency and evenness of operation.
- Tighten loose connections.

EVERY 10 CARRIER HOURS OR AT LEAST ONCE A WEEK

- Remove the tool retaining pin and the tool for inspection. Grind the burrs away, if necessary. See “Changing the tool” on page 61.
- Check that the tool has received sufficient greasing. Adjust greasing setting more frequently, if necessary.

EVERY 50 CARRIER HOURS OR AT LEAST ONCE A MONTH

- Check the tool shank and tool bushings for wear. See “Changing the tool” on page 61. See “Changing the lower tool bushing” on page 64.
- Check the hydraulic hoses. Replace if necessary. Do not let dirt get into the hammer or hoses.
- Check that the impact unit moves normally inside the housing and that vibration dampening elements (pads and buffers) are in good condition.
- Check the condition of the wear plates. Move the impact unit from side to side in the housing with a pry bar to check the clearance. The maximum allowed clearance is approximately ± 10 mm.

1.3 INSPECTION AND MAINTENANCE BY THE DEALER

Note: The times given refer to the carrier hours while the attachment is installed.

INITIAL 50-HOUR INSPECTION

It is recommended to have the first inspection done by your local dealer after 50 to 100 operating hours. Contact your local dealer for more information about the initial 50-hour inspection.

PERIODIC OR ANNUAL SERVICE MAINTENANCE

In general, have this regular service performed every 1000 carrier operating hours or once a year, whichever comes first.

If your hammer has a remote monitoring device, have this regular service performed every 800 hammer work hours or once a year, whichever comes first.

Neglecting the periodic or annual service can cause severe damage to the hammer.

During this service, your local dealer will replace all seals, accumulator membranes, and any damaged safety decals. Contact your local dealer for more information about this servicing.

For this maintenance, you should also perform the following tasks:

- Check all hydraulic connections.
- Check that the hydraulic hoses do not rub against anything in any boom position.
- Inspect the hydraulic oil filters of the carrier and replace if needed.

1.4 MAINTENANCE INTERVALS IN SPECIAL APPLICATIONS

The service interval is considerably shorter in special applications. See “Special conditions of use” on page 41. In special applications, consult your local dealer for the recommended service intervals.

MAINTENANCE INTERVALS IN UNDERWATER USE

After every half hour of carrier operation

- Grease the tool shank and the tool bushings through the grease nipples.
- Check that the impact unit moves normally inside the housing and that the buffers are in good condition.
- Check all hoses and connections.
- Check the operation of the air pressure switch.

Daily maintenance

- Remove the tool retaining pin and the tool for inspection. Grind burrs away, if necessary.
- Check that the tool has received sufficient grease.
- Service the hammer after underwater jobs.

The hammer must be totally dismantled and serviced after working under water.

Neglecting a hammer service after underwater work can cause severe damage to the hammer.



The hammer, as a standard assembly, must not be used under water. If water fills the space where the piston strikes the tool, a strong pressure wave is generated and the hammer may be damaged.

1.5 OTHER MAINTENANCE PROCEDURES

WASHING THE ATTACHMENT

When working with attachment and removing it from the carrier, dirt (mud, rock powder etc.) can become attached to it. Wash the outside of the product with a steam washer before sending it to the workshop. Dirt can cause difficulties in disassembly and assembly otherwise.

CAUTION! Plug the pressure and return line and other connections before washing the product or else dirt can enter into it and this may cause damage to the components.

2. CHANGING THE TOOL

WEAR LIMITS AND LUBRICANTS FOR TOOL REMOVAL

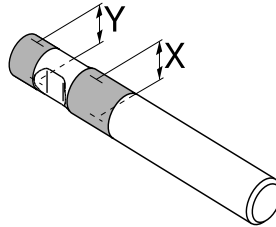

R030045

| Item | Wear limit |
|----------------------------|------------------|
| Tool diameter X (worn out) | 113 mm (4.45 in) |
| Tool diameter Y (worn out) | 104 mm (4.09 in) |

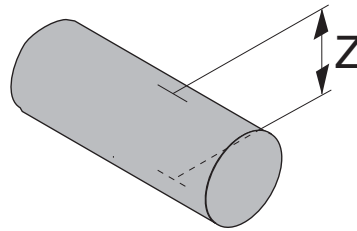

R030149

| Item | Wear limit |
|--|-----------------|
| Tool retaining pin diameter Z (worn out) | 46 mm (1.81 in) |

| Item | Lubricant |
|------------------------------|-------------|
| Tool and tool retaining pins | Tool grease |

REMOVAL OF TOOL



Warning! The hydraulic pressure inside the hammer must always be released before removing the tool. After operating the hammer, wait 10 minutes for oil pressure to drop inside hammer.

Warning! Hot tool can cause severe injuries.



Do not throw used hammer tool away at job site. Used tools can be recycled by delivering them to an authorized scrap metal collection facility.

1. Set the hammer on level ground.
2. Make sure the carrier's transmission is in neutral and the parking brake is engaged.
3. Stop the carrier engine.
4. Remove plugs.
5. Remove rubber rings.
6. Remove tool retaining pins by using t-puller.

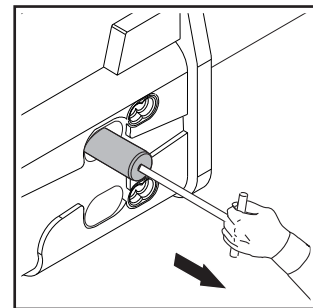
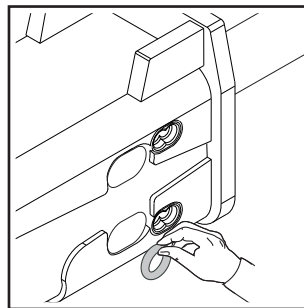
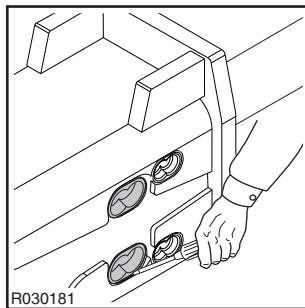

7. Remove tool. Use lifting device if necessary. See “Tool specifications” on page 81.

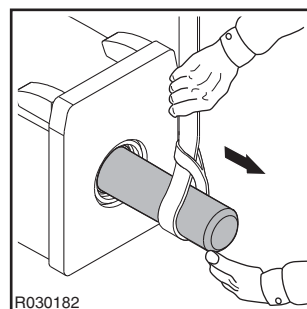

Note: If hammer is still on carrier, it may be easier to stick the tool in the ground and lift the hammer off the tool. Make sure that the tool cannot fall.

INSTALLATION OF TOOL

1. Clean all parts carefully.
2. Measure the tool diameters (X and Y) from the areas marked on the illustration. Replace tool if necessary. See “Changing the tool” on page 61.
3. Measure the tool retaining pin diameter (Z). Replace tool if necessary. See “Changing the tool” on page 61.
4. Check the tool seal surface condition. If seal is damaged replace it.
5. Check the shape of the seal. It should be round, not oval in shape.
6. Measure seal inner diameter from area with most wear. Replace it if not as specified.
7. If the shape develops oval, the seal should be removed from its groove and the groove cleaned thoroughly. If old seal is reinstalled, diameter needs to be checked again.
8. When seal is replaced with new, make sure surface of the tool is in good condition (on the tool sealing area). Smoothen with emery cloth (grit size P120...P150), if necessary.

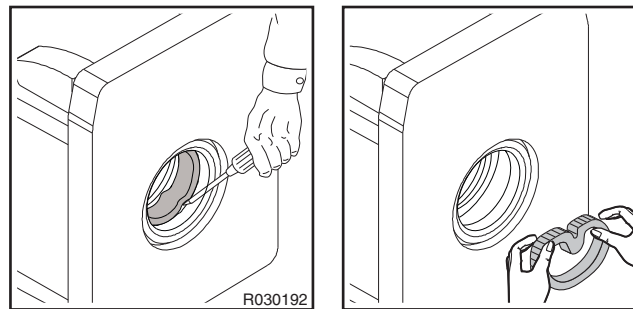

9. Clean the tool and retaining pins and lubricate them with tool grease.
10. Install tool and align the grooves of the tool with the pin bores.
11. Install tool retaining pins.
12. Install rubber rings.
13. Install plugs.

3. CHANGING THE LOWER TOOL BUSHING

WEAR LIMITS AND LUBRICANTS FOR LOWER TOOL BUSHING

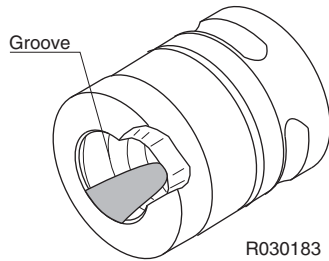

| Item | Wear limit |
|-------------------------|--|
| Tool bushing (worn out) | First three grease grooves are worn out. Bushing must be replaced. |

| Item | Lubricant |
|---|---------------|
| Contact surfaces of front head and wedges | Thread grease |

LOWER TOOL BUSHING EXTRACTION TOOL

The lower tool bushing extraction tool can be used for pulling out the lower tool bushing (Puller arrangement) or for pushing in the lower tool bushing (Pusher arrangement). See illustrations 1. for Puller arrangement and 2. for Pusher arrangement.

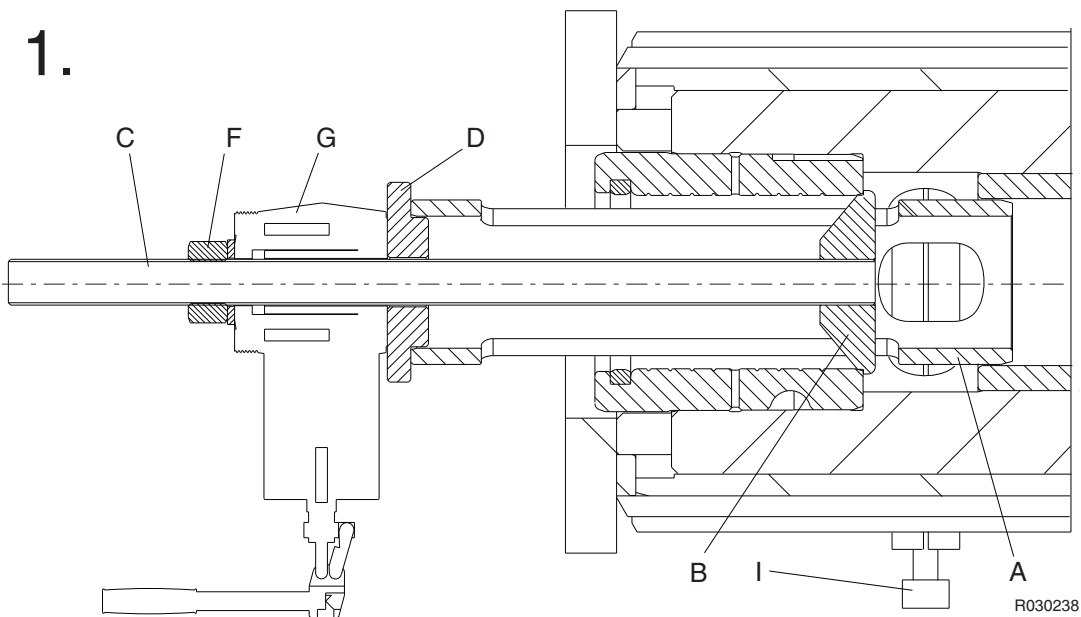

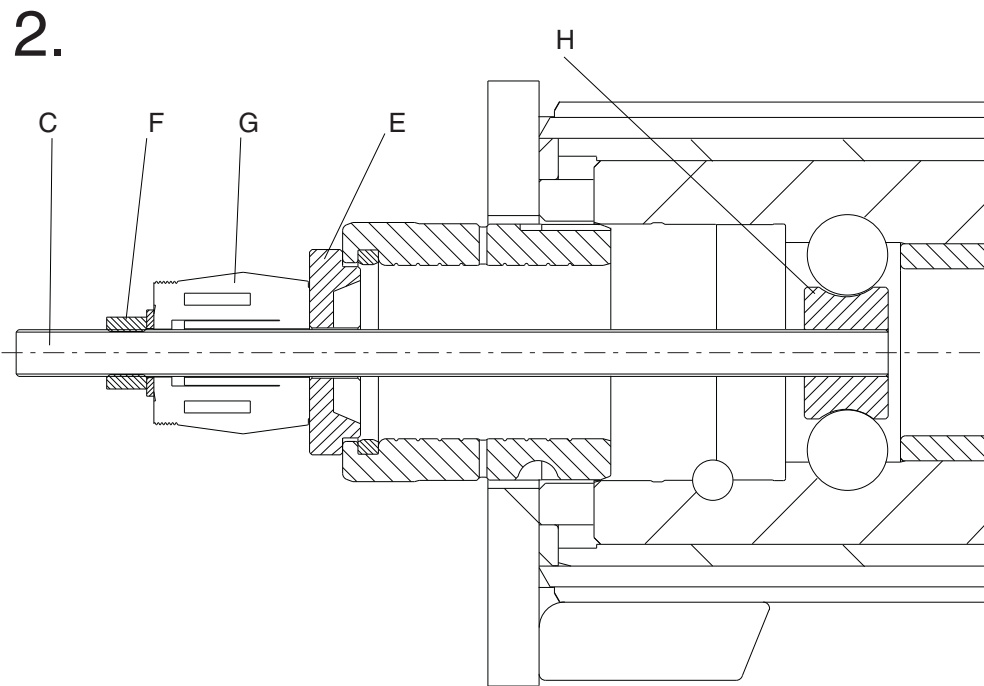

R030239

- A. Puller frame
- B. Puller plate
- C. Screw
- D. Plate
- E. Plate
- F. Nut
- G. Hydraulic hole cylinder
- H. Locking plate
- I. Wedge

Note: Contact your local dealer for more information on these parts.

REMOVAL OF LOWER TOOL BUSHING

Do not throw used hammer tool bushing away at job site. Used tool bushings can be recycled by delivering them to an authorized scrap metal collection facility.

1. Remove tool.
2. Remove rubber plugs.
3. Remove rubber rings.
4. Remove retaining pins.

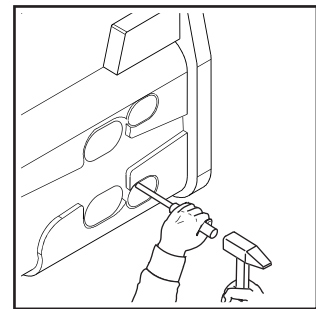
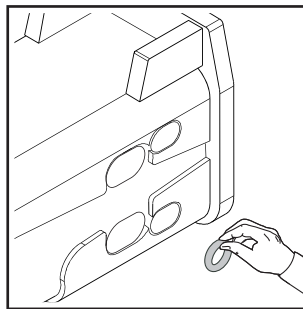
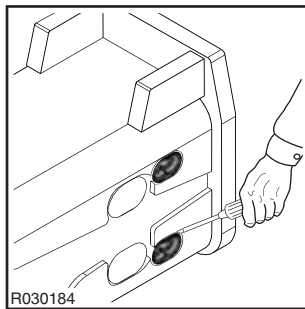

5. Remove tool seal.

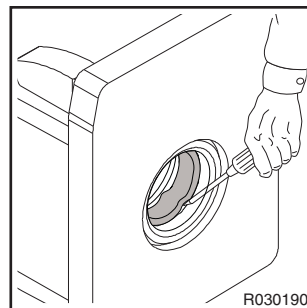

6. Install puller frame inside the lower tool bushing.
7. Install puller plate inside puller frame behind the lower tool bushing.
8. Apply thread grease on contact surfaces of wedge and lock puller frame with wedges.

9. Install screw to puller plate.

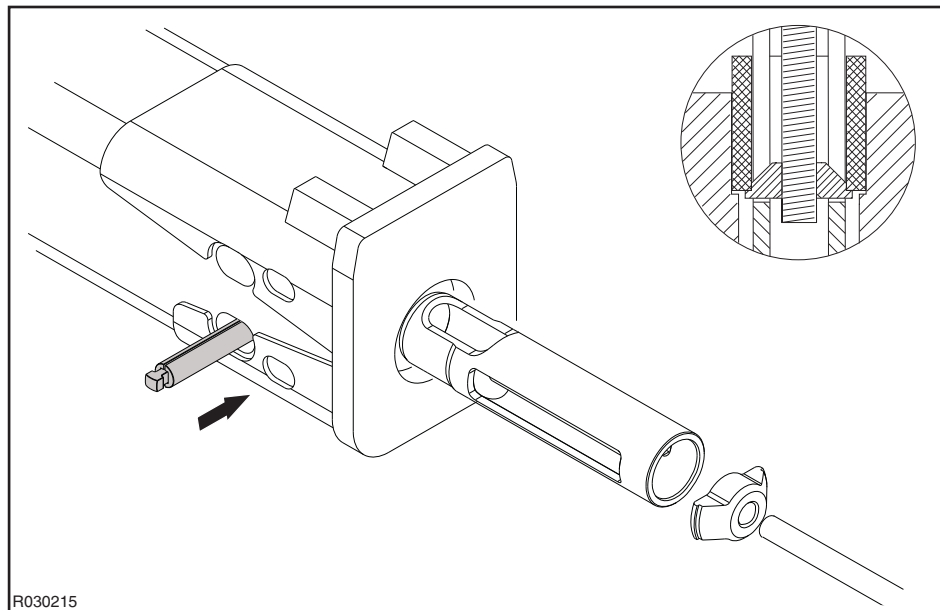

10. Install plate, hole cylinder and nut.

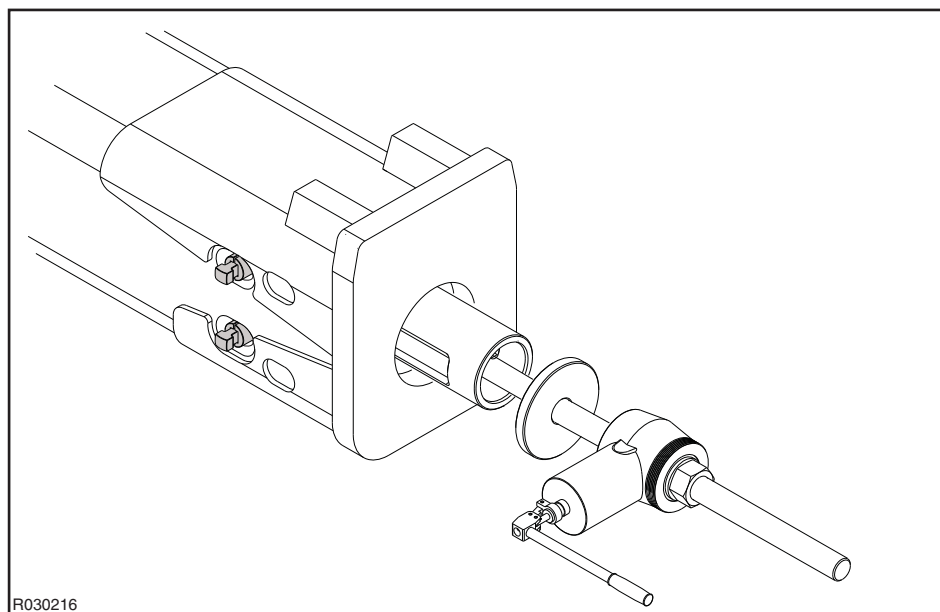

11. Pull lower tool bushing out by using hydraulic hole cylinder. If tool bushing is stick, loose screw and hit wedges with a sledge hammer to loose lower tool bushing and then pull lower tool bushing out.

12. Remove plate, hole cylinder and nut.

13. Remove lower tool bushing.

14. Remove wedges.

15. Remove puller frame, screw and puller plate.

INSTALLATION OF LOWER TOOL BUSHING

1. Clean and dry all parts carefully. Check all parts for cracks and excessive wear. See wear limits for thrust ring and upper tool bushing in specifications section. See “Changing the lower tool bushing” on page 64.
2. Replace or rotate the lower tool bushing. Note: If the lower tool bushing is worn out, replace it with a new one. However, if the lower tool bushing does not exceed wear limits and is still usable, you can rotate it 90 degrees and reinstall it.
3. Apply thread grease on contact surfaces of lower tool bushing and front head.
4. Install lower tool bushing to the front head. Align grooves and screw in the front head and grooves in the lower tool bushing
5. Install locking plate.
6. Lock locking plate with tool retaining pins.
7. Install screw.

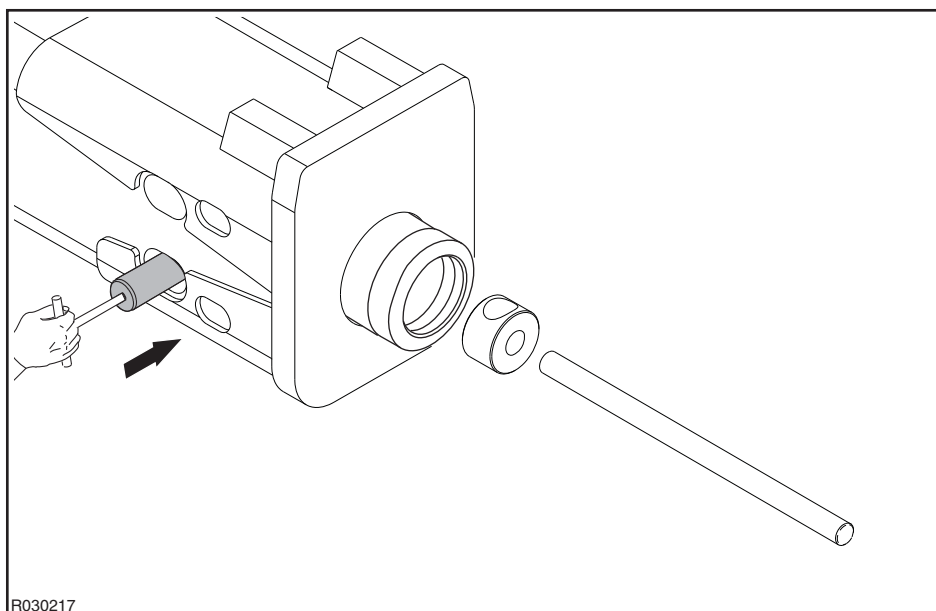

8. Install plate, hole cylinder and nut.

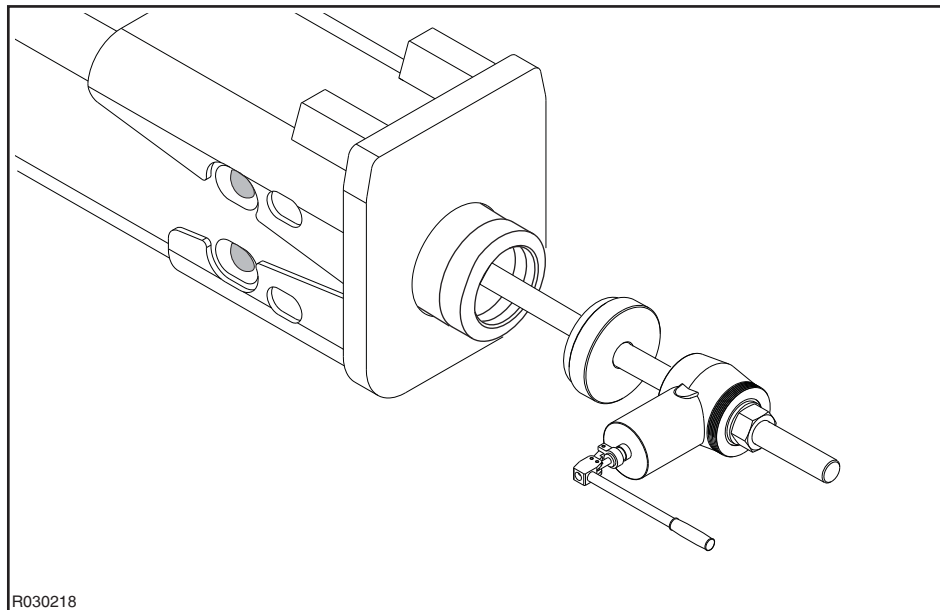

9. Push lower tool bushing in with hole cylinder.

10. Install retaining pins.

11. Install rubber rings.

12. Install rubber plugs.

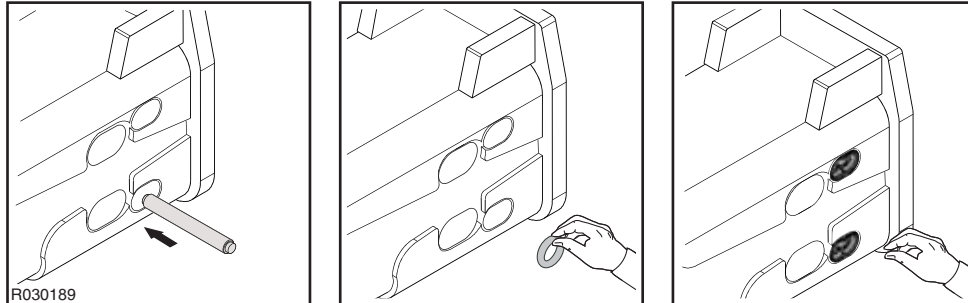

13. Remove tool retaining pins and tool bushing's assembly tool.

14. Install new seal. Make sure surface of the tool is in good condition (on the tool sealing area). Smoothen with emery cloth (grit size P120...P150), if necessary.

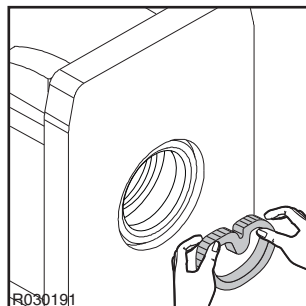

15. Install the tool.

4. TROUBLESHOOTING

4.1 THE HAMMER DOES NOT START

PRESSURE OR RETURN LINES CLOSED

Check the operation of quick couplings in hammer line. Open hammer line ball valves if closed.

PRESSURE AND RETURN HOSES INSTALLED BACKWARDS

Swap the pressure and return hoses.

IDLE BLOW PROTECTION TURNED ON AND FEEDING FORCE IS TOO LOW

Turn Idle Blow Protection off or increase feeding force against object.

PISTON IS IN ITS LOWER HYDRAULIC BRAKE

Keep the hammer control valve open and force the tool against an object. The tool head will push the piston out of its brake area. See “Daily operation” on page 32.

GREASE BETWEEN PISTON AND TOOL CONTACT AREA

Remove the tool and wipe excessive grease off. See “Manual greasing” on page 50.

HAMMER CONTROL VALVE DOES NOT OPEN

When operating the hammer control valve, check that the pressure line pulsates (this indicates the hammer control valve is opening). If the valve does not operate, check the operating means: mechanical connections, pilot pressure and electrical control.

RELIEF VALVE IN HYDRAULIC CIRCUIT OPENS AT A LOW PRESSURE. HAMMER OPERATING PRESSURE IS NOT REACHED

Check the installation. Check the relief valve operation. Adjust the relief valve in hydraulic circuit. Measure the high pressure in the hammer inlet line. Contact your local dealer for more information.

EXCESSIVE BACK PRESSURE IN RETURN LINE

Check the installation. Check the size of the return line.

LEAKAGE FROM PRESSURE TO RETURN IN EXCAVATOR HYDRAULIC CIRCUIT

Check the installation. Check the pump and the other hydraulic components.

FAILURE IN HAMMER VALVE OPERATION

The hammer must be serviced in an authorized Rammer service shop.

PISTON FAILURE

The hammer must be serviced in an authorized Rammer service shop.

4.2 THE HAMMER OPERATES IRREGULARLY BUT THE BLOW HAS FULL POWER

NOT ENOUGH FEED FORCE FROM EXCAVATOR

Refer to the correct working methods. See “Daily operation” on page 32.

RELIEF VALVE IN HYDRAULIC CIRCUIT OPENS AT A LOW PRESSURE. HAMMER OPERATING PRESSURE IS NOT REACHED

Check the installation. Check the relief valve operation. Adjust the relief valve in hydraulic circuit. Measure the high pressure in the hammer inlet line. Contact your local dealer for more information.

FAILURE IN HAMMER VALVE OPERATION

The hammer must be serviced in an authorized Rammer service shop.

FAILURE IN GREASING DEVICE HYDRAULIC CIRCUIT

Oil leakage. The hammer must be serviced in an authorized Rammer service shop.

4.3 THE HAMMER OPERATES IRREGULARLY AND BLOW HAS NO POWER

THE WORKING METHOD IS NOT CORRECT

Refer to the correct working methods. See “Daily operation” on page 32.

RELIEF VALVE IN HYDRAULIC CIRCUIT OPENS AT A LOW PRESSURE. HAMMER OPERATING PRESSURE IS NOT REACHED

Check the installation. Check the relief valve operation. Adjust the relief valve in hydraulic circuit. Measure the high pressure in the hammer inlet line. Contact your local dealer for more information.

PRESSURE CONTROL VALVE SETTING IS INCORRECT

The hammer must be serviced in an authorized Rammer service shop.

PRESSURE LOSS IN PRESSURE ACCUMULATOR

The hammer must be serviced in an authorized Rammer service shop.

FAILURE IN HAMMER VALVE OPERATION

The hammer must be serviced in an authorized Rammer service shop.

4.4 IMPACT RATE SLOWS DOWN

OIL HAS OVERHEATED (OVER +80 °C/+176 °F)

Check for a fault in the oil cooling system or an internal leak in the hammer. Check the hydraulic circuit of the carrier. Check the relief valve operation in the carrier. Check the line size. Assemble an extra oil cooler.

HYDRAULIC OIL VISCOSITY TOO LOW

Check hydraulic oil. See “Requirements for hydraulic oil” on page 52.

EXCESSIVE BACK PRESSURE IN RETURN LINE

Check the installation. Check the size of the return line.

RELIEF VALVE IN HYDRAULIC CIRCUIT OPENS AT A LOW PRESSURE. HAMMER OPERATING PRESSURE IS NOT REACHED

Check the installation. Check the relief valve operation. Adjust the relief valve in hydraulic circuit. Measure the high pressure in the hammer inlet line. Contact your local dealer for more information.

LEAKAGE FROM PRESSURE TO RETURN IN EXCAVATOR HYDRAULIC CIRCUIT

Check the installation. Check the pump and the other hydraulic components.

OIL FLOW FROM THE CARRIER IS TOO HIGH

The hammer is equipped with a built-in Ramvalve which is designed to decrease oil flow to the hammer when oil flow from the carrier is too high. If impact rate is too slow check the oil flow. Contact your local carrier dealer for more information.

PRESSURE LOSS IN PRESSURE ACCUMULATOR

The hammer must be serviced in an authorized Rammer service shop.

FAILURE IN HAMMER VALVE OPERATION

The hammer must be serviced in an authorized Rammer service shop.

4.5 THE HAMMER DOES NOT STOP OR HAS RUN-ON

INTERNAL OIL LEAK IN THE HAMMER

The hammer must be serviced in an authorized Rammer service shop.

FAILURE IN HAMMER CONTROL VALVE OPERATION

Check the hammer control valve in the carrier.

4.6 OIL OVERHEATS

APPLICATION NOT CORRECT FOR HAMMER

Refer to recommended use and to correct working methods. See “Daily operation” on page 32.

COOLING CAPACITY OF THE OIL COOLER IS TOO SMALL

Assemble an extra oil cooler.

RELIEF VALVE IN HYDRAULIC CIRCUIT OPENS AT A LOW PRESSURE. HAMMER OPERATING PRESSURE IS NOT REACHED

Check the installation. Check the relief valve operation. Adjust the relief valve in hydraulic circuit. Measure the high pressure in the hammer inlet line. Contact your local dealer for more information.

HYDRAULIC OIL VISCOSITY TOO LOW

Check hydraulic oil. See “Requirements for hydraulic oil” on page 52.

LEAKAGE FROM PRESSURE TO RETURN IN EXCAVATOR HYDRAULIC CIRCUIT

Check the installation. Check the pump and the other hydraulic components.

INTERNAL OIL LEAK IN THE HAMMER

The hammer must be serviced in an authorized Rammer service shop.

EXCESSIVE BACK PRESSURE IN RETURN LINE

Check the installation. Check the size of the return line.

4.7 RECURRENT TOOL FAILURE

APPLICATION NOT CORRECT FOR HAMMER

Refer to recommended use and to correct working methods. See “Operating instructions” on page 27.

ROUGH OPERATING PRACTICES

Refer to recommended use and to correct working methods. See “Daily operation” on page 32.

TOOL DOES NOT GET ENOUGH LUBRICANT

Refer to recommended use and to correct working methods.

TOO LONG TOOL

Use shortest tool possible. Refer to recommended use and to correct working methods.

RAPID WEAR OF TOOL

Refer to recommended use and to correct working methods. See “Daily operation” on page 32. There is a wider selection of tools available for different applications. Consult with your local dealer for more information.

4.8 AUTOMATIC GREASING DEVICE PROBLEMS

UPPER OR LOWER TOOL BUSHING DOES NOT GET ENOUGH LUBRICANT

- Cold conditions. Apply grease from grease gun to grease nipples.
- Doser adjustment is wrong for the application. The doser must be readjusted.
- Blockage in greasing device. Contact your local dealer for more information.

UPPER OR LOWER TOOL BUSHING GETS TOO MUCH LUBRICANT

- Doser adjustment is wrong for the application. The doser must be readjusted.
- Leak in the doser. The doser must be replaced. Contact your local dealer for more information.

TOOL DOES NOT GET LUBRICANT AT ALL

- Grease cartridge is empty or damaged. Replace the grease cartridge. See “Automatic greasing” on page 47.
- Doser defective. The doser must be replaced. Contact your local dealer for more information.
- Leak in the grease hose or pressure hose. Inspect the hoses and replace if necessary.
- Grease and pressure hoses are installed backwards. Swap the hoses.
- To continue troubleshooting, disconnect the grease hose from the hammer valve body and operate the hammer. After 10 minutes of operation check if grease has protruded from the grease hose.

LUBRICATION DEVICE IS WORKING (WHILE THE GREASE HOSE IS DISCONNECTED)

- Leak in hammer lubrication channel. The hammer must be serviced in an authorized Rammer service shop.
- Hammer lubrication channel is blocked. The hammer must be serviced in an authorized Rammer service shop.

LUBRICATION DEVICE DOES NOT WORK (WHILE THE GREASE HOSE IS DISCONNECTED)

- Remove the lubrication device from the hammer and deliver it for service in an authorized Rammer service shop.

4.9 FURTHER ASSISTANCE

FURTHER ASSISTANCE

If further assistance is required, please prepare to answer the following questions before calling your dealer.

- Model and serial number
- Working hours and service history
- Remote monitoring device report if available
- Carrier model
- Installation: Oil flow, operating pressure and return line pressure if known
- Application
- Has the product operated normally before

SPECIFICATIONS

1. HAMMER SPECIFICATIONS

1.1 TECHNICAL SPECIFICATIONS

| Item | Specification |
|---|--------------------------------------|
| Minimum working weight ¹ | 1100 kg (2430 lb) |
| Hammer weight | 890 kg (1960 lb) |
| Impact rate ² | 540...920 bpm |
| Operating pressure ³ | 135...145 bar (1960...2105 psi) |
| Pressure relief, min ⁴ | 190 bar (2755 psi) |
| Pressure relief, max | 220 bar (3190 psi) |
| Oil flow range | 90...130 l/min (23.8...34.3 gal/min) |
| Back pressure, max | 10 bar (145 psi) |
| Input power | 31 kW (42 hp) |
| Tool diameter | 115 mm (4.53 in) |
| Pressure line connection (IN) | SAE 6000 psi 1" |
| Return line connection (OUT) | SAE 6000 psi 1" |
| Grease connection (G) ⁵ | BSPP-internal 3/8" |
| Air connection (A) ⁶ | BSPP-internal 3/8" |
| Pressure line size (minimum inner diameter) | 26 mm (1.02 in) |
| Return line size (minimum inner diameter) | 26 mm (1.02 in) |
| Optimum oil temperature | 40...60 °C (104...140 °F) |
| Allowed oil temperature range | -20...80 °C (-4...176 °F) |
| Optimum oil viscosity at operating temperature | 30...60 cSt |
| Allowed oil viscosity range | 20...1000 cSt |
| Carrier weight ⁷ | 12...20 t (26500...44100 lb) |
| Noise level, measured sound power level, LWA ⁸ | 123 dB |
| Noise level, guaranteed sound power level, LWA ⁹ | 127 dB |

1. Includes average mounting bracket and standard tool
2. Actual impact frequency depends on oil flow, oil viscosity, temperature, and material to be broken
3. Actual pressure depends on oil flow, oil viscosity, temperature, material to be broken and back pressure
4. Minimum setting = actual operating pressure + 50 bar (730 psi)
5. Located on the same side of the valve body as the return line (OUT) connection
6. Located on the same side of the valve body as the pressure line (IN) connection
7. Check carrier's lifting capacity from carrier manufacturer
8. According to European Union DIRECTIVE 2000/14/EC
9. According to European Union DIRECTIVE 2000/14/EC

1.2 MAIN DIMENSIONS

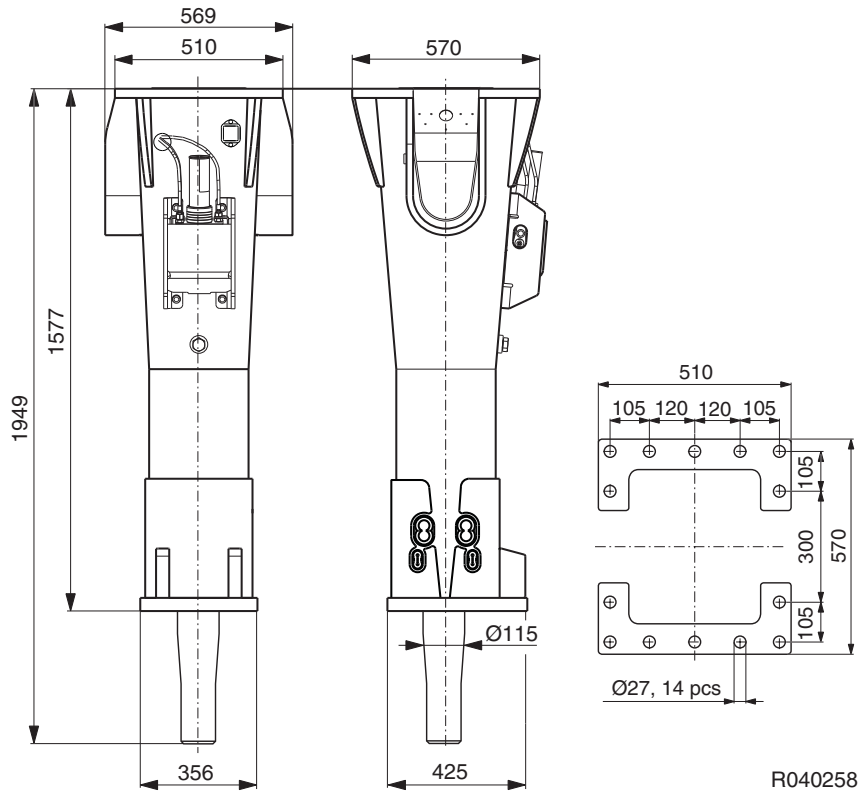

1.3 MOUNTING BRACKET SPECIFICATIONS

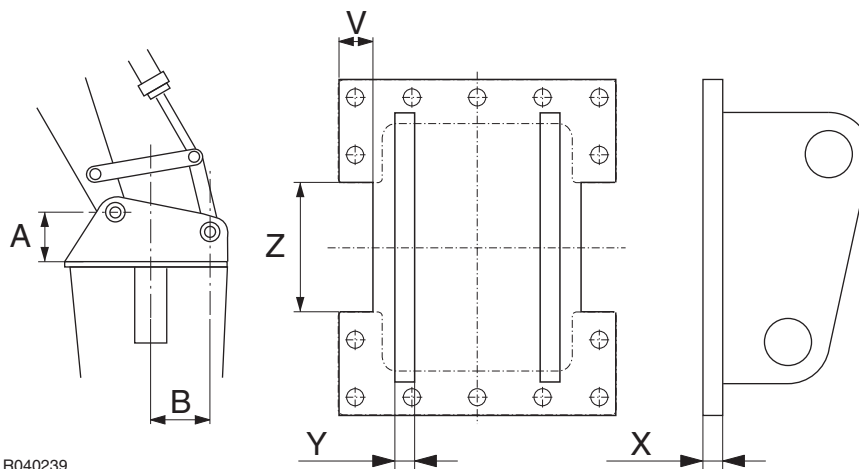

R040239

| Item | Specification |
|---|------------------|
| Bottom plate, recommended minimum thickness (X) | 25 mm (0.98 in) |
| Side plate, recommended minimum thickness (Y) | 25 mm (0.98 in) |
| Width of the opening for pressure hose (Z) | 200 mm (7.87 in) |
| Depth of the opening for pressure hose (V) | 60 mm (2.36 in) |

Note: After welding, check the flatness of the plate and mill surface as needed. The maximum acceptable deviation from flatness is 1 mm (0.04 in).

Consider the following when designing mounting brackets

Required plate thicknesses.

Correct transport position of the hammer.

Most common hammering position, in which the bucket cylinder is in the middle position.

Mechanical stops to protect the bucket cylinder when the hammer is fully in or out

Placement of the pin holes on the mounting bracket hinges. Normally, they are placed almost symmetrically from the hammer center line.

Height of the stick's mounting bracket pin from the mounting bracket bottom plate (A). The height depends on how close the pin is to the hammer center line. The closer it is, the longer dimension (A) must be.

Effect of hammer recoil and feed force on the bucket cylinder, which should be minimized. This effect depends on distance (B). The longer distance (B) is, the smaller the effect.

2. TOOL SPECIFICATIONS

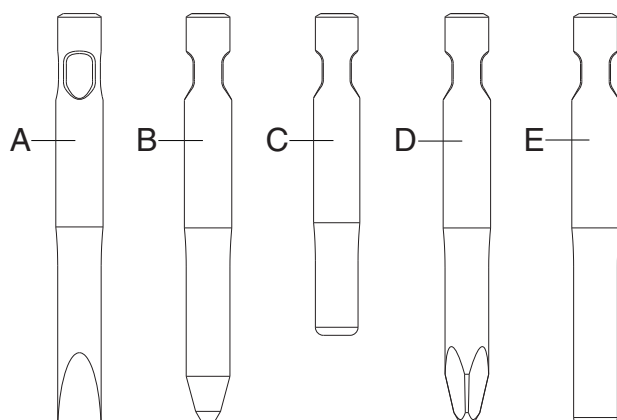

R040285

| Tool | Part no. | Length | Weight | Diameter |
|----------------|----------|-----------------------|----------------|---------------------|
| Chisel (A) | BB49E1 | 1000 mm (39.37 in) | 67 kg (150 lb) | 115 mm (4.53 in) |
| Moil point (B) | BB49E3 | 1000 mm (39.37 in) | 68 kg (150 lb) | 115 mm (4.53 in) |
| Blunt (C) | BB49E4 | 800 mm (31.50 in) | 58 kg (130 lb) | 115 mm (4.53 in) |
| Pyramid (D) | BB49E3K3 | 1000 mm (39.37 in) | 66 kg (150 lb) | 115 mm (4.53 in) |
| Long blunt (E) | BB49E4C1 | 1000 mm (39.37 in) | 72 kg (160 lb) | 115 mm (4.53 in) |

There is a wider selection of tools available for different applications. Consult with your local dealer for more information.

3. COMPLIANCE

3.1 EU DECLARATION OF CONFORMITY

EU DECLARATION OF CONFORMITY

Original

(Directive 2006/42/EC, Annex II. 1. A; Directive 2000/14/EC)

Manufacturer: Sandvik Mining and Construction Oy, Breakers Lahti

Address: Taivalkatu 8, FI-15170 Lahti, Finland

Herewith declares that the Rammer hydraulic hammer

Model: 1655E

- **Is in conformity with all the relevant provisions of the Machinery Directive 2006/42/EC.**
- **Is in conformity with all the relevant provisions of the Outdoor Equipment Noise Directive 2000/14/EC.**

The procedure applied for conformity assessment is "Internal control of production" (Annex V).

| Model | Serial number | Measured sound power level: LWA [dB] | Guaranteed sound power level: LWA [dB] |
|-------|---------------|---|---|
| 1655E | 1655EA | 123 | 127 |

- **And the following (parts/clauses of) standards have been applied:**

EN ISO 12100 - Safety of machinery, General principles for design, Risk Assessment and risk reduction

DNV GL certified quality management system according to ISO 9001, Design and manufacture of product

Technical file and manufacturing conformity

N.N., Director R&D/E, is authorized to compile the technical file and confirms the product design to conform with the essential health and safety requirements.

M.M., Director Supply, confirms compliance of the manufactured machinery with the technical file.

N.N. and M.M. are empowered to draw up this declaration of conformity.

Signed for and on behalf of Sandvik Mining and Construction Oy, Breakers Lahti

Place: Taivalkatu 8, FI-15170 Lahti, Finland

Date: dd.mm.yyyy

Signed: N.N.

Director R&D/E

Signed: M.M.

Director Supply

3.2 UK DECLARATION OF CONFORMITY

UK DECLARATION OF CONFORMITY

Original

Manufacturer: Sandvik Mining and Construction Oy, Breakers Lahti

Address: Taivalkatu 8, FI-15170 Lahti, Finland

Herewith declares that the Rammer hydraulic hammer

Model: 1655E

- **Is in conformity with the relevant provisions of the Supply of Machinery (Safety) Regulations 2008 No. 1597, as amended.**
- **Is in conformity with all the relevant provisions of the Noise Emission in the Environment by Equipment for use Outdoors Regulations 2001 No. 1701, as amended:**

| Model | Serial number | Measured sound power level: LWA [dB] | Guaranteed sound power level: LWA [dB] |
|-------|---------------|---|---|
| 1655E | 1655EA | 123 | 127 |

- **And the following (parts/clauses of) standards have been applied:**

EN ISO 12100 - Safety of machinery, General principles for design, Risk Assessment and risk reduction

DNV GL certified quality management system according to ISO 9001, Design and manufacture of product

Technical file and manufacturing conformity

N.N., Director R&D/E, is authorized to compile the technical file and confirms the product design conforms with the essential health and safety requirements.

M.M., Director Operations, confirms compliance of the manufactured machinery with the technical file.

N.N. and M.M. are empowered to draw up this declaration of conformity.

Signed for and on behalf of Sandvik Mining and Construction Oy, Breakers Lahti

Place: Taivalkatu 8, FI-15170 Lahti, Finland

Date: dd.mm.yyyy

Signed: N.N.

Director R&D/E

Signed: M.M.

Director Operations



Sandvik Mining and Construction Oy, Breakers Lahti
Taivalkatu 8, P.O. Box 165, FI-15101 Lahti, Finland
Phone Int. +358 205 44 151, Telefax Int. +358 205 44 150
www.rammer.com